

TYPICAL

GT680 SERIES

LOCKSTITCH BAR TACKER

INSTRUCTION BOOK
PARTS CATALOGUE

A. Machine body

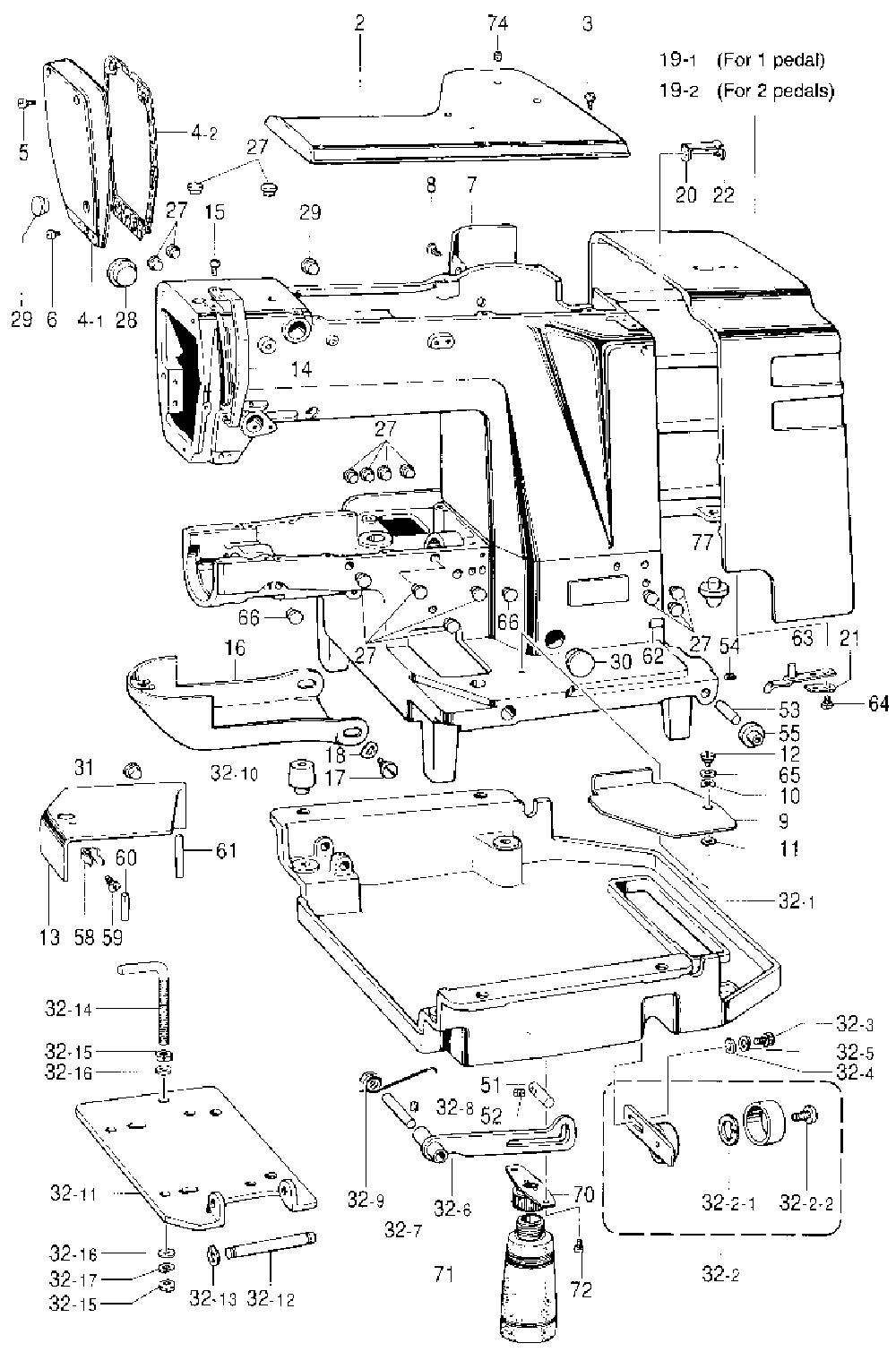

A. Machine body

No.	Ret. No.	Description	Qty.
2	B958270901	Top cover	1
3	B048349698	Screw, pan SM5.95 – 28 × 14	4
4	B958279001	Face plate assy	1
4 – 1	B958278901	Face plate	1
4 – 2	B958277009	Packing	1
5	B048399698	Screw, pan SM4.76 – 32 × 14	2
6	B048390398	Screw, pan SM4.76 – 32 × 7	1
7	B958276001	Frame side cover	1
8	B048399698	Screw, pan SM4.76 – 32 × 14	4
9	B958275001	Bed cover (R)	1
10	B900795008	Washer	1
11	B085330878	Washer, plain M8.35	1
12	B965620909	Shoulder screw, SM6.35	1
13	B958273901	Bed cover, L	1
14	B958269801	Cover, ; T/take – up lever	1
15	B048430298	Screw, pan SM3.57 – 40 × 8	1
16	B958268051	Shuttle race cover assy	1
17	B99617008	Shoulder screw, SM5.95	2
18	B901871008	Washer, wave spring	2
19 – 1	BX74423001	< For 1 pedal> Belt cover	1
19 – 2	BX74421001	< For 2 pedals> Belt cover, C	1
20	B958121009	Spring, plate	1
21	BX74410009	Spring hook	1
22	B048420298	Screw, pan SM4.37 – 40 × 8	1
27	B993174009	Rubber cap, 9.4	15
28	B980718001	Oil cap	1
29	B993176009	Rubber cap, 13.5	2
30	B902580009	Rubber cap, 19.8	1
31	B906850909	Rubber cap, 8	1
32	B951202901	Oil pan assy	1
32 – 1	B956372901	Oil pan	1
32 – 2	B958258909	Tension pulley assy	1
32 – 2 – 1	B082780868	Retaining ring, internal C32	1
32 – 2 – 2	B969240009	Screw, SM6.35	1
32 – 3	B092029888	Bolt, socket M8 × 12	1
32 – 4	B085020878	Washer, plain M 8	1
32 – 5	B082020868	Washer, spring 2 – 8	1
32 – 6	B958253009	Head support lever	1
32 – 7	B958252009	Head support lever shaft	1
32 – 8	B097991698	Set screw, (CP) SM4.76	1
32 – 9	B958251009	Spring	1
32 – 10	B958240001	Bed cushion	4
32 – 11	B958249909	Motor base plate	1
32 – 12	B958248009	Motor base plate shaft	1
32 – 13	B082900968	Retaining ring, external C10	2
32 – 14	B958245809	Bolt, L – type M10	1
32 – 15	B089900808	Nut, 2 M10	2
32 – 16	B085900978	Washer, plain S10	2
32 – 17	B082900868	Washer, spring 2 – 10	1
51	B958244009	Head supporter pin	1
52	B097340498	Set screw, (CP) SM5.95	1
53	B958243000	Hinge shaft	2
54	B959406008	Set screw, SM5.95	2
55	B958242001	Hinge cushion	2
58	B996125009	Spring, plate	1
59	B048420498	Screw, pan SM4.37 – 40 × 6	1

A. Machine body

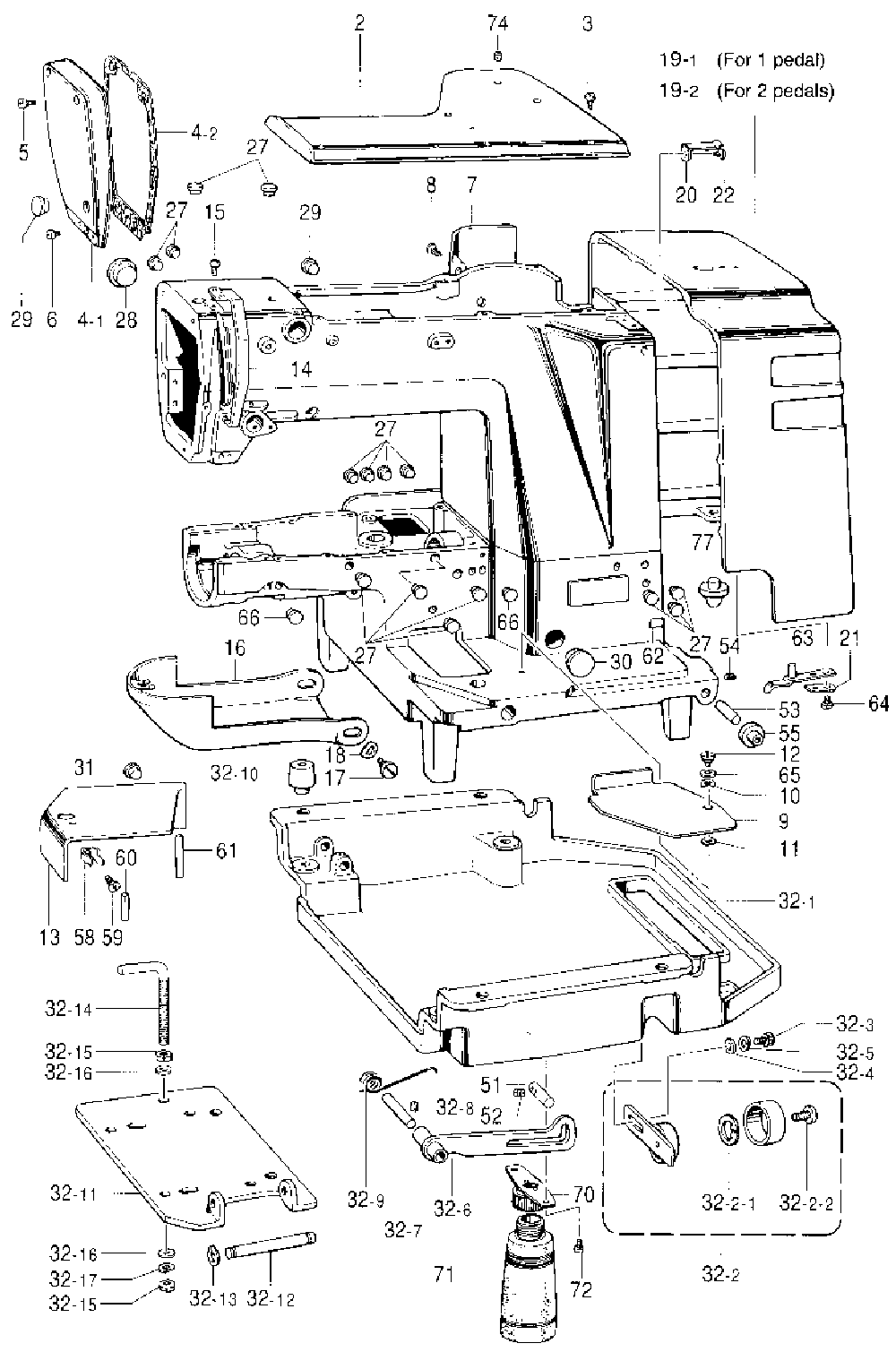

A. Machine body

No.	Ret. No.	Description	Qt.
60	B958272009	Dowel pin	1
61	B958271009	Bed cover shaft	1
62	*	Label	1
63	B958262009	Spring, plate	1
64	B048429898	Screw, pan SM4. 37 – 40 x 14	2
65	B085020978	Washer, plain S 8	1
66	B906650909	Rubber cap, 8	2
70	B956645009	Dust oiler support assy	1
71	B996624008	Oiler	1
72	B048390498	Screw, pan SM4. 76 – 32 x 6	2
74	B956325000	Felt	1
77	B958263001	Packing	2

B. Clutch mechanism

No.	Ret. No.	Description	Qt.
1	B959224009	Clutch lever	1
2	B959183009	Felt, ; clutch	1
3	B959223009	Clutch lever shaft	1
4	B062920968	Retaining ring, external C18	1
5	BX76209009	Washer, plain 18	1
6	B096289088	Set screw, socket (CP) SM7. 94	1
7	BX73788000	Thrust washer, 18	1
8	BX76207009	Washer, plain 8	1
9	B959947009	Bolt, socket M8 x 15	1
10	B959222909	Ball presser plate	1
11	B092028588	Bolt, socket M8 x 25	2
12	B082020868	Washer, spring 2 - 8	2
13	B995098008	Set screw, SM6. 35	1
14	B950558008	Nut, SM6. 35	1
15	B959221009	Clutch stopper	1
16	B959210000	Stopper rubber	1
17	B959219009	Spring	1
18	BX76204009	Spring holder	1
19	B995092009	Cushion rubber	2
20	B085200778	Washer, plain L7. 14	1
21	B959217009	Stopper shaft	1
22	B089200908	Nut, 1 SM7. 14	1
23	B900010006	Nut, SM7. 14	1
24	B959216909	Brake lever	1
25	B959215000	Brake assy	1
26	B959212009	Brake shaft	1
27	B062060762	Retaining ring, E4	2
28	B959211009	Spring	1
29	B959100009	Brake lever shaft	1
30	BX76206009	Washer	2
31	B062990968	Retaining ring, external C11	2
32	B096340488	Set screw, socket SM5. 95	1
33	BX79775009	Brake slide pin assy	1
33 - 1	BX79774009	Brake slide pin	1
33 - 2	BX00387009	Collar 7. 94	1
33 - 3	B957626009	Washer, plain 4. 76	1
33 - 4	B062060768	Retaining ring, E4	1
34	B096340488	Set screw, socket SM5. 95	1
35	B959108009	Spring	1
36	B959107009	Spring hook screw	1
37	B904963008	Nut, SM7. 94	1
38	B990859009	Spring hook	1
39	B959106909	Clutch lever rod assy	1
39 - 1	B959105909	Clutch lever rod	1
39 - 2	B903366009	Roller	1
39 - 3	B959104909	Roller shaft	1
39 - 4	B062070768	Retaining ring, E3	1
39 - 5	B997879008	Washer, plain	1
39 - 6	B085420978	Washer, plain S 4. 37	1
39 - 7	B089420808	Nut, 2 SM4. 37	1
40	B959103009	Stud screw 5. 95	1
41	B959102009	Nut, SM5. 95	1
42	B955509009	Spring	1
43	B959190009	Spring hook	1
44	B993747009	Bolt, SM4. 76	2
45	B082050868	Washer, spring 2 - 5	2
46	B958202909	Adjust rod assy	1
46 - 1	B956778009	Presser bar lifter adjust rod	1
46 - 2	B956777009	Presser bar lifter adj. joint	1
46 - 3	B950554009	Nut, SM6. 35	1

B. Clutch mechanism

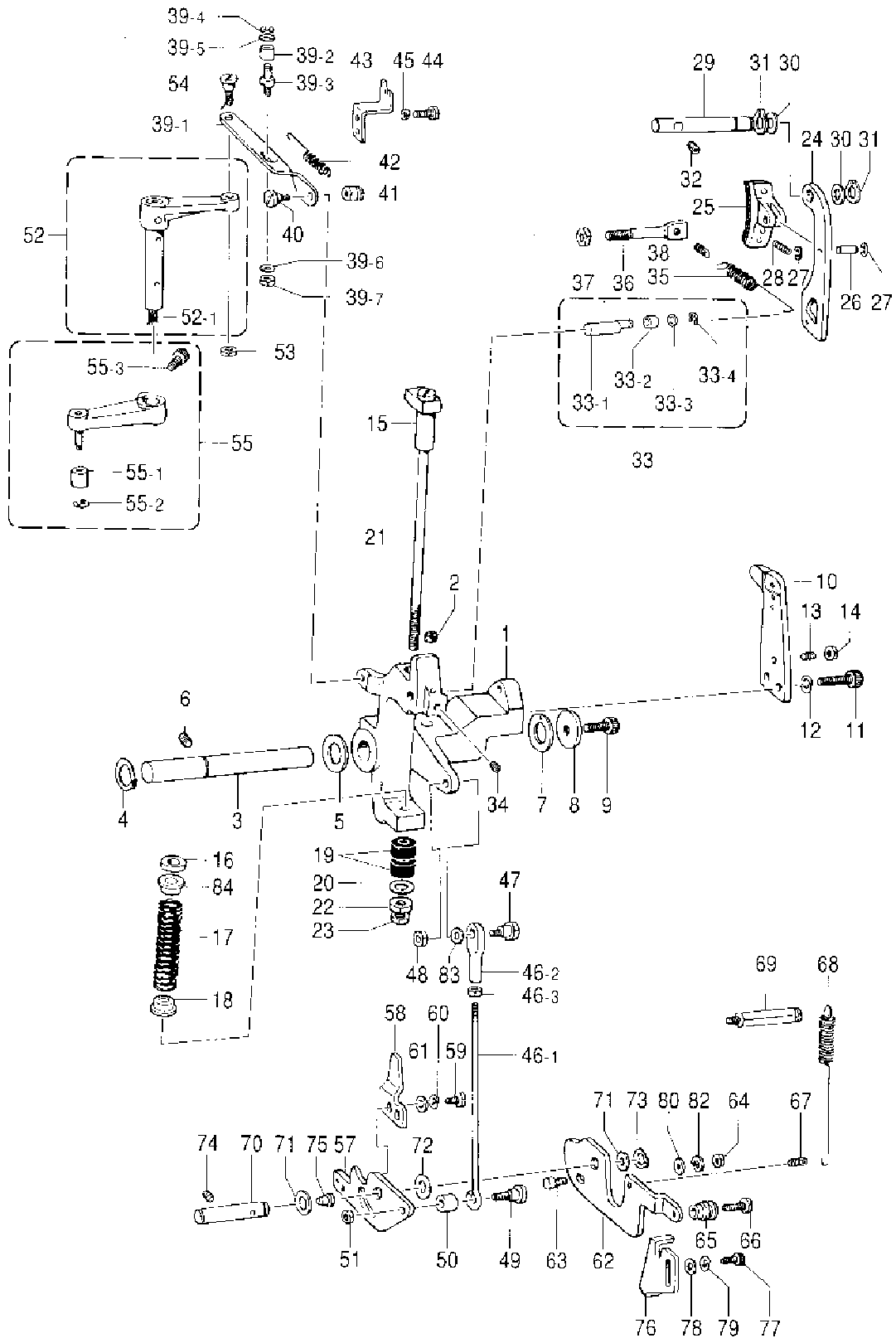

B. Clutch mechanism

No.	Ret. No.	Description	Qt.
47	B959198009	Stud screw 6. 35	1
48	B950554009	Nut, SM6. 35	1
49	B959197009	Stud screw 6. 35	1
50	B959196009	Collar 13	1
51	B950554009	Nut, SM6. 35	1
52	B959195909	Clutch actuating lever assy	1
52 - 1	B958120009	Wick 6 × 6(L = 150)	1
53	B950557009	Nut, SM5. 95	1
54	B959103009	Stud screw 5. 95	1
55	B959171909	Clutch cam lever assy	1
55 - 1	B958196009	Roller	1
55 - 2	B082060787	Retaining ring, E4	1
55 - 3	B092048578	Bolt, socket M6 × 25	1
57	B959191909	Starting lever	1
58	B959180009	Starting safety lever	1
59	B093399698	Bolt, SM4, 76 × 14	2
60	B082050868	Washer, spring 2 - 5	2
61	B997679008	Washer, plain	2
62	B955811009	Starting lever plate	1
63	B956955909	Stopper screw	1
64	B950557009	Nut, SM5. 95	1
65	B959188009	Chain hook collar	1
66	B093348808	Bolt, SM5. 95 × 22	1
67	B990859009	Spring hook	1
68	B959187009	Spring	1
69	B959186009	Spring hook	1
70	B959185009	Starting lever shaft	1
71	B968482009	Spacer	2
72	B990505009	Washer	1
73	B082990968	Retaining ring, external C11	1
74	B096340488	Set screw, socket SM5. 95	1
75	B999245001	Cap, 6	1
76	B955500009	Starting lever stopper	1
77	B092049488	Bolt, socket M6 × 16	2
78	B085040978	Washer, plain S 6	2
79	B082040868	Washer, spring 2 - 6	2
80	B085040878	Washer, plain M 6	1
82	B082040868	Washer, spring 2 - 6	1
83	BX07415009	Washer, plain 6	1
84	B959218009	Spring hook	1

C. Upper shaft and needle bar mechanism

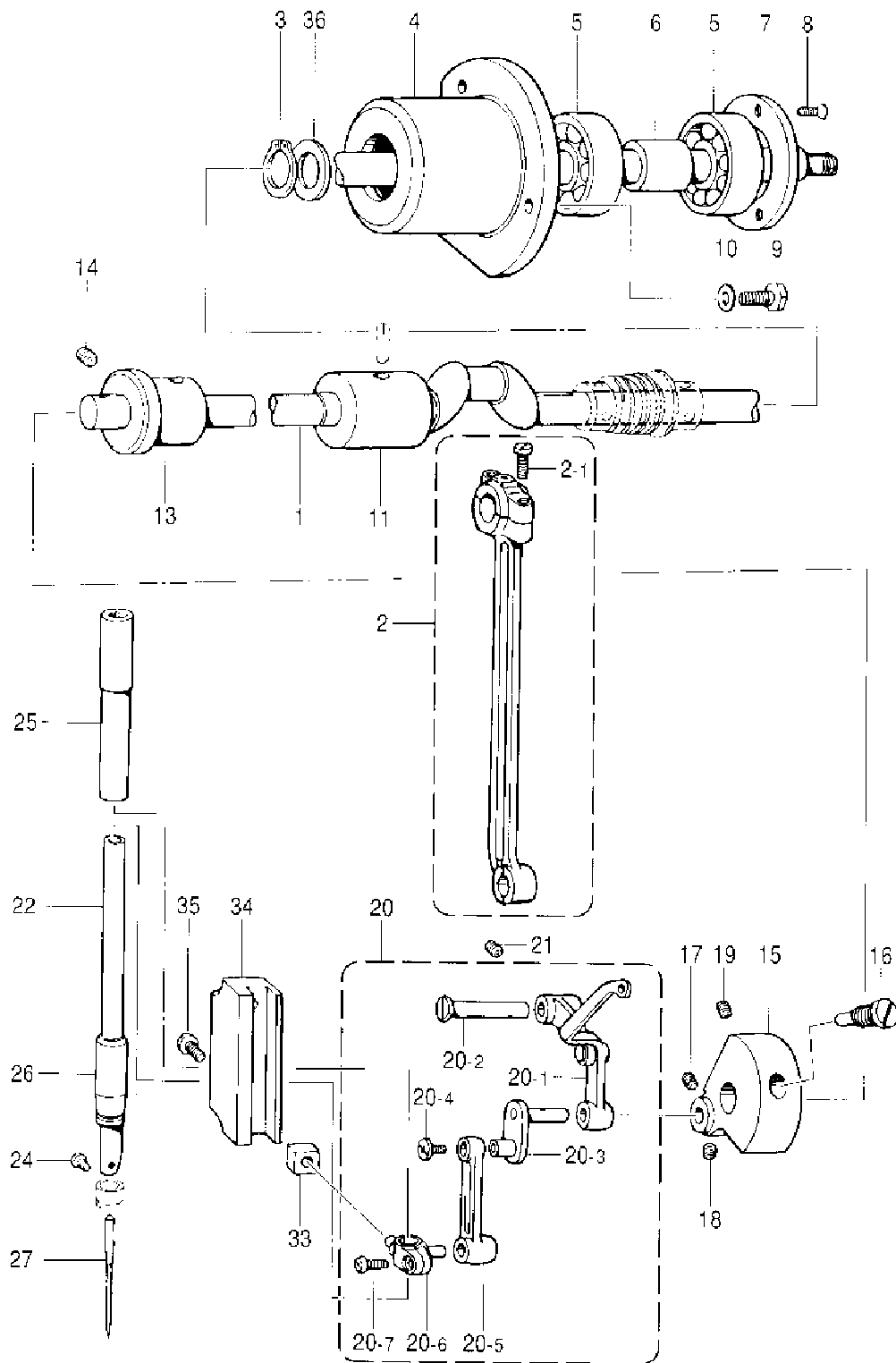

C. Upper shaft and needle bar mechanism

No.	Ret. No.	Description	Qty.
1	BX72774009	Upper shaft	1
2	B957060009	Crank rod assy	1
2-1	B986398009	Screw, SM4.76	2
3	B082950968	Retaining ring, external C15	1
4	B959113000	Ball bearing case	1
5	B038470840	Ball bearing, 6302W	2
6	B959112000	Bearing collar	1
7	B959111009	Ball bearing cap	1
8	B908267006	Screw, flat SM3.57	3
9	BX71990009	bolt, W/socket SM5.95-28 x 14	3
10	B085040878	Washer, plain M 6	3
11	B980384000	Bush, M ; U - shaft	1
13	B958000009	Upper shaft bush(F)	1
14	B096340478	Set screw, socket (CP) SM5.95 x 6	1
15	B958879000	Thread take - up crank	1
16	B900850009	Screw, SM7.14	1
17	B096330488	Set screw, socket (CP) SM6.35	1
18	B909304009	Set screw, SM6.35-40 x 5.5	1
19	B096330488	Set screw, socket (CP) SM6.35	1
20	B958878909	Thread take - up lever set	1
20-1	B957770909	Thread take - up lever assy	1
20-2	B958874009	Support shaft, TR/take - up	1
20-3	B958873909	Needle bar crank	1
20-4	B978059009	Screw, flat SM3.57-40 x 7 L	1
20-5	B958872009	Needle bar connecting rod	1
20-6	B958871009	Needle bar clamp	1
20-7	B048420298	Screw, pan SM4.37-40 x 8	1
21	B096340478	Set screw, socket (CP) SM5.95 x 6	1
22	B958860909	Needle bar, A	1
24	B986662009	Set screw, SM3.57-40 x 4.5	1
25	B958868009	Bush, U ; N - bar	1
26	B958867009	Bush, D ; N - bar	1
27	*	Needle, DP	1
33	B988899009	Slide block	1
34	B958866000	Needle bar guide	1
35	B048329698	Screw, pan SM6.35-28 x 14	2
36	B994180009	Ring, thrust	1

D. Drive pulley and idler pulley mechanism

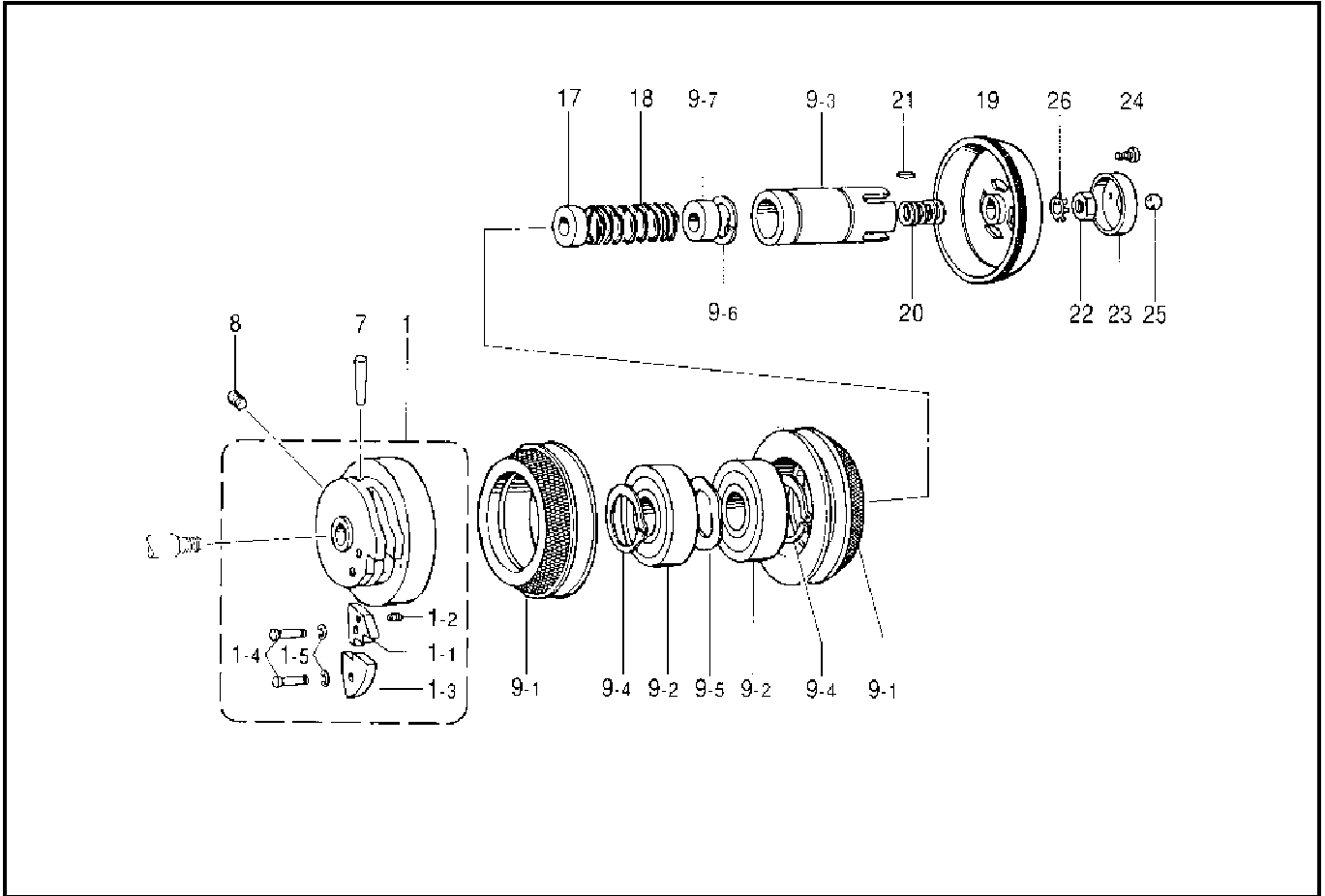

E. Supply parts

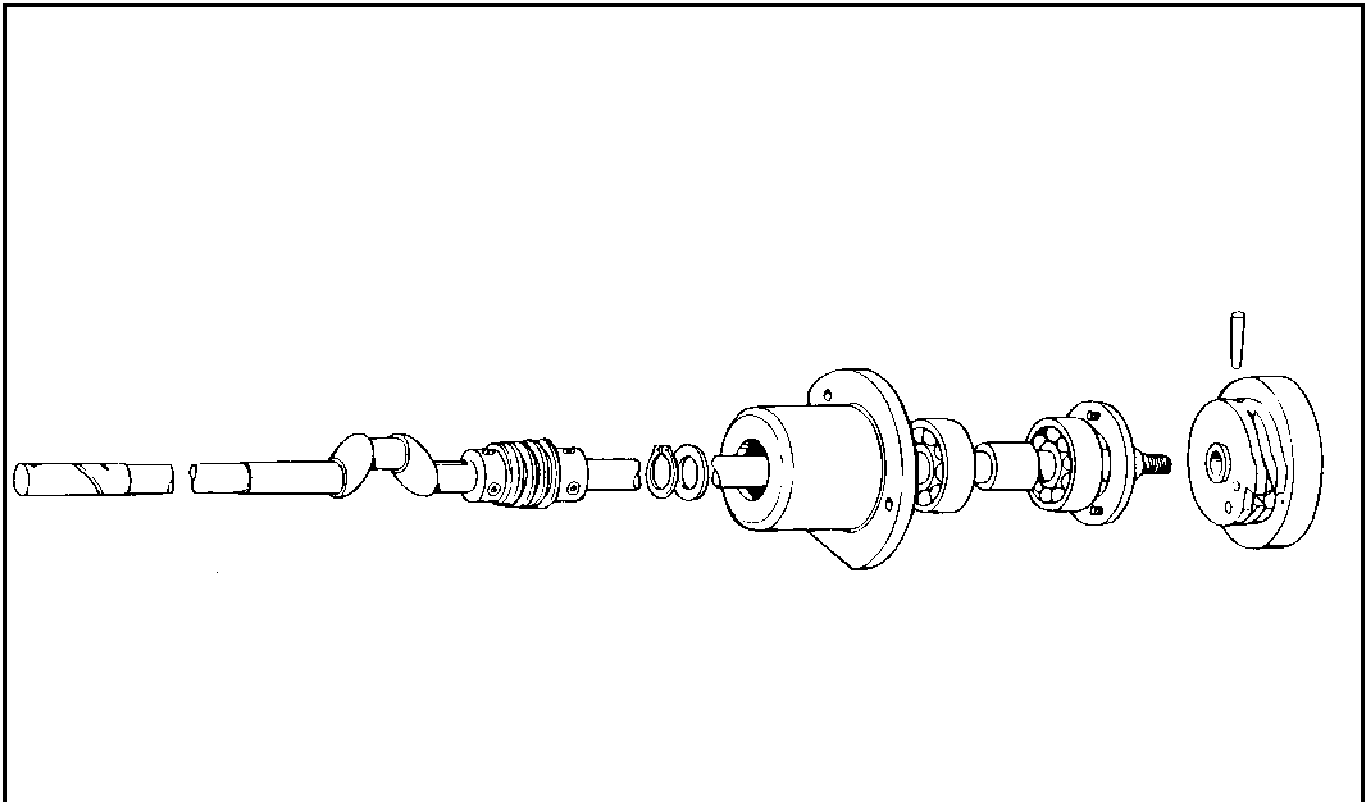

D. Drive pulley and idler pulley mechanism

No.	Ret. No.	Description	Qt.
1	B957066909	Stop cam assy	1
1-1	B958417009	Brake cam segment	1
1-2	B958416009	Spring	1
1-3	BX75373009	Flange cam segment	1
1-4	B957062009	Cam segment stud	2
1-5	B062060768	Retaining ring, E4	2
7	B963999009	Pin, taper 6 × 35	1
8	B096330488	Set screw, socket (CP) SM6.35	1
9	B927424909	Pulley set	1
9-1	B958415809	Pulley device assy	2
9-2	B038400340	Ball bearing, 6007VV	2
9-3	B958412909	Slide bush	1
9-4	B062750968	Retaining ring, external C35	2
9-5	B958411009	Washer	1
9-6	B062860868	Retaining ring, internal C24	1
9-7	B958300000	Slide bush (A)	1
17	B959164000	Slide bush (B)	1
18	B958309009	Spring	1
19	B958308009	Clutch plate	1
20	B958307900	Spacer	5
21	BX08232000	Key 3 × 3 × 13	1
22	B958305909	Nut 10	1
23	B958304909	Ball holder	1
24	B048440398	Screw, pan SM3.18 – 40 × 7	2
25	B039015850	Bearing ball, 3/8	1
26	BX89980009	Washer	1

E. Supply parts

No.	Ret. No.	Description	Qt.
	BX73779009	Upper shaft assembly B430	1

F. Feed mechanism

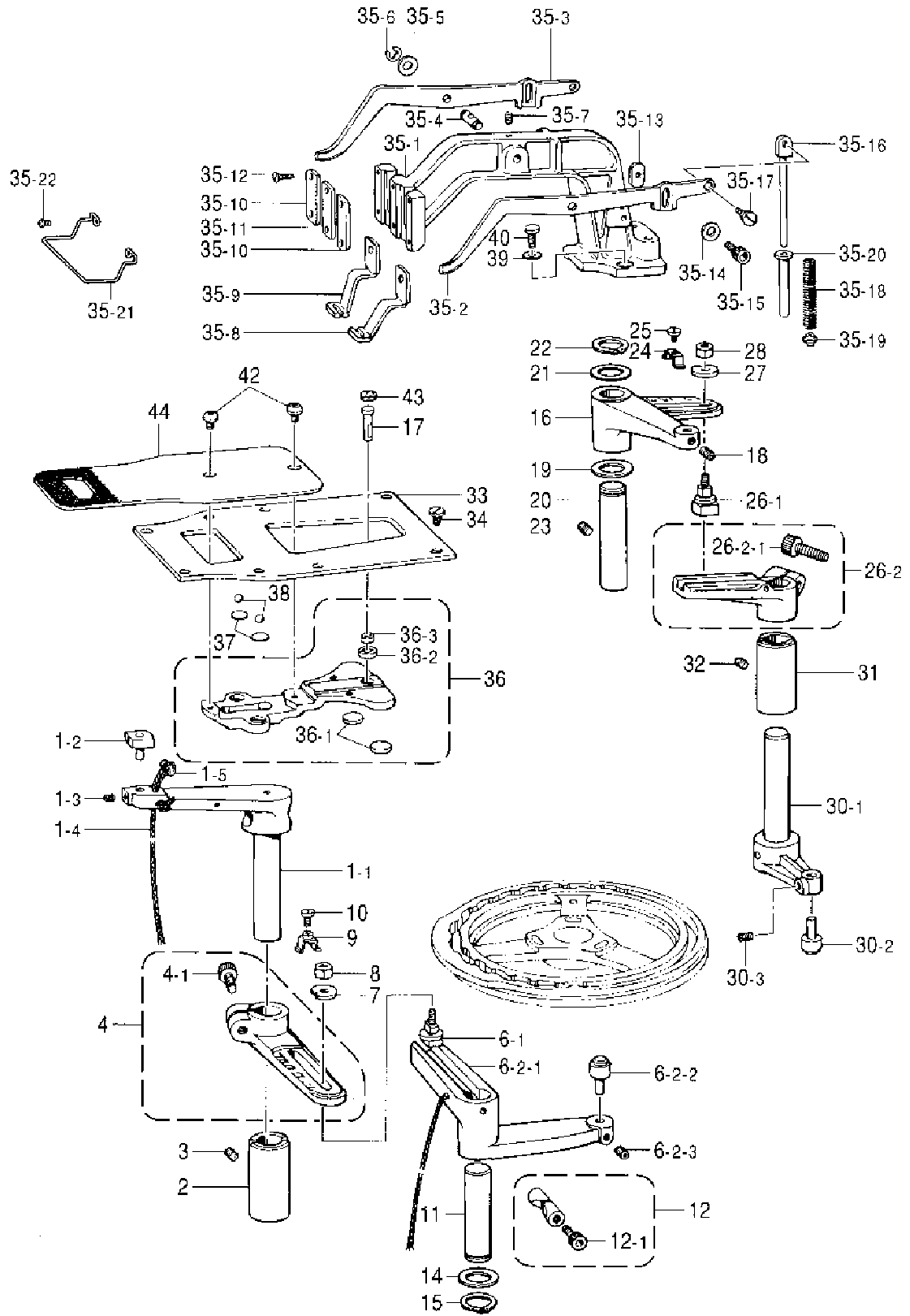

F. Feed mechanism

No.	Ret. No.	Description	Qty.
1	B958369809	Tack length lever assy	1
1-1	B958368909	Tack length lever	1
1-2	B957069009	Slide block assy, ; T-length	1
1-3	B959408008	Set screw, SM4. 37-40 x8	1
1-4	B957186009	Felt	1
1-5	B957189009	Wick, 4 x4 L=150	1
2	B958365009	Feed bush	1
3	B096340488	Set screw, socket SM5. 95	1
4	B957348809	T-length regulator lever assy	1
4-1	B092028088	Bolt, socket M8 x20	1
6	B957063009	Tack length regulator assy	1
6-1	B957068009	Tack regulator shaft assy	1
6-2-1	B958368009	Tack length lever	1
6-2-2	B957067009	Feed cam roller shaft assy	1
6-2-3	B096340488	Set screw, socket SM5. 95	1
7	B958361009	Washer	1
8	B958350009	Adjusting nut	1
9	B957065009	Tack length lever stopper	1
10	B905669008	Screw, SM3. 57	1
11	B958355009	Tack length lever shaft	1
12	BX01978059	Pinch sleeve assy	1
12-1	B092047088	Bolt, socket M8 x30	1
14	B958354009	Washer, thrust 18	1
15	B062920968	Retaining ring, external C18	1
16	B958352009	Tack width feed lever	1
17	B958351009	Tack width feed shaft	1
18	B096340488	Set screw, socket SM5. 95	1
19	B958354009	Washer, thrust 18	1
20	B958340059	Lever shaft	1
21	B958354009	Washer, thrust 18	1
22	B062920268	Retaining ring, external C18	1
23	B096340488	Set screw, socket SM5. 95	1
24	B957065009	Tack length lever stopper	1
25	B905669008	Screw, SM3. 57	1
26	B957062009	Tack width regulator lever assy	1
26-1	B957068009	Tack regulator shaft assy	1
26-2	B957353009	Tack width adjust lever assy	1
26-2-1	B092028088	bolt, socket M8 x20	1
27	B958361009	Washer	1
28	B958350009	Adjusting nut	1
30-1	B957779909	Tack width feed shaft assy	1
30-2	B957067009	Feed cam roller shaft assy	1
30-3	B096340488	Set screw, socket SM5. 95	1
31	B958365009	Feed bush	1
32	B096340488	Set screw, socket SM5. 95	1
33	B958344009	Feed bar guide plate	1
34	B965792009	Screw, SM4. 37	8
35	*	Work clamp arm assy	1
35-1	BX61518900	Work clamp arm	1
35-2	B958336009	Presser arm lever (R)	1
35-3	B958335009	Presser arm lever (L)	1
35-4	BX76271009	Lever shaft	1
35-5	B994481009	Washer	2
35-6	B062050768	Retaining ring, E5	2
35-7	B096340488	Set screw, socket SM5. 95	1
35-8	*	Work clamp, U-R	1
35-9	*	Work clamp, U-L	1
35-10	B958327009	Work clamp guide bracket, A	2
35-11	B958326009	Work clamp guide bracket, B	1
35-12	B903072007	Screw, flat SM3. 57	4

F. Feed mechanism

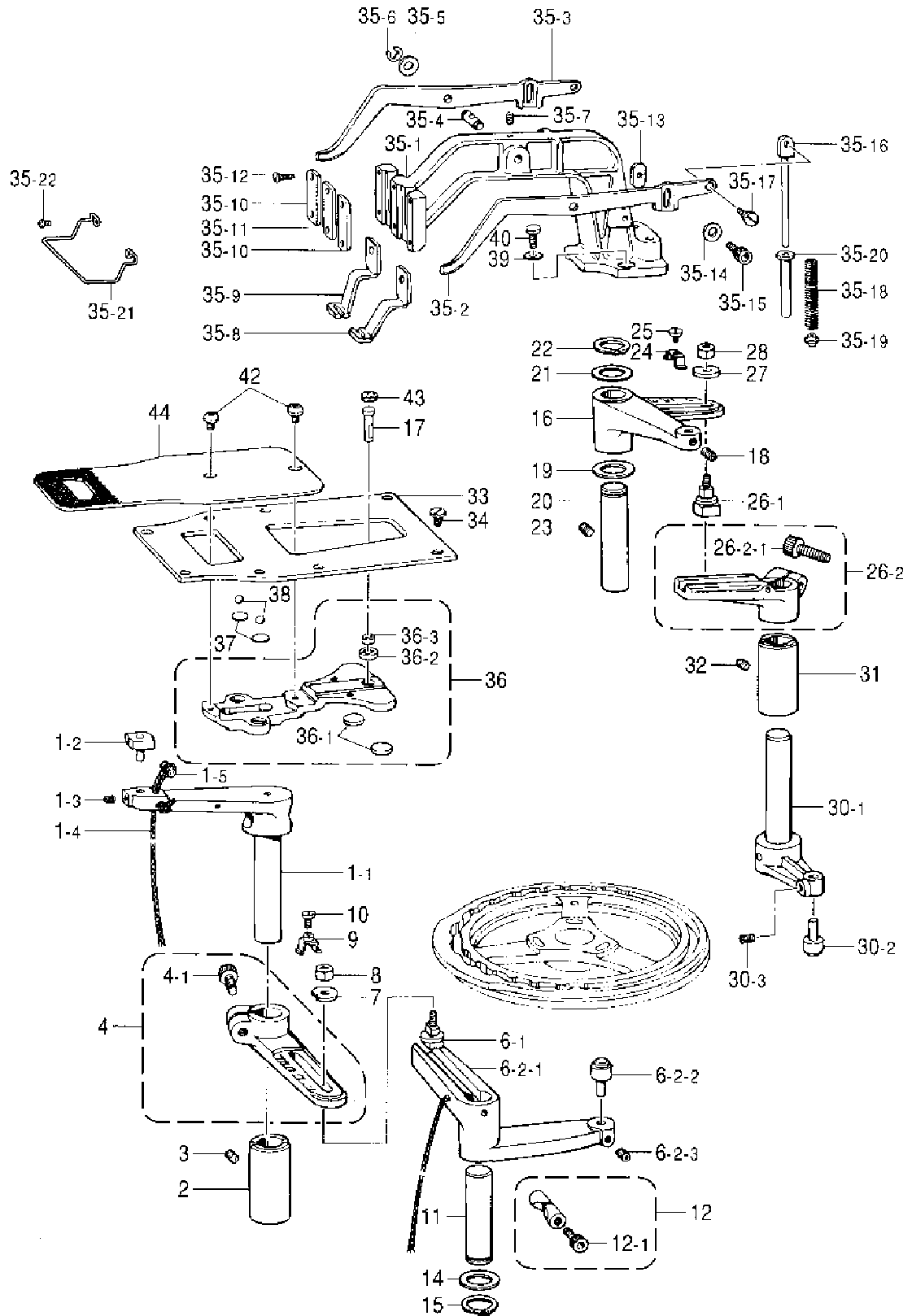

F. Feed mechanism

No.	Ret. No.	Description	Qty.
35 - 13	B957539009	Presser arm lever plate	2
35 - 14	B964756009	Washer, plain 5	2
35 - 15	B092500288	Bolt, socket M5 x 8	2
35 - 16	B957530009	Spring guide rod	2
35 - 17	B965632909	Shoulder screw, socket SM4. 76	2
35 - 18	*	Spring, A ; compression	2
35 - 19	B958322000	Spacer	2
35 - 20	B957543000	Collar	2
35 - 21	B954615809	Finger guard	1
35 - 22	B048439098	Screw, pan SM3. 57 - 40 x 10	2
36	B958341909	Feed bracket assy	1
36 - 1	B958339000	Washer	2
36 - 2	B958337000	Bush	1
36 - 3	B969779009	Bush	1
37	B958338009	Spacer	2
38	B039063450	Steel ball, 3/16	2
39	B085040878	Washer, plain M 6	2
40	BX71990009	Bolt, W/socket SM5. 95 - 28 x 14	2
42	B957056908	Screw, round W/socket SM4. 37	2
43	B957075000	Felt	1
44	*	Feed plate	1

G. Work clamp lifter mechanism

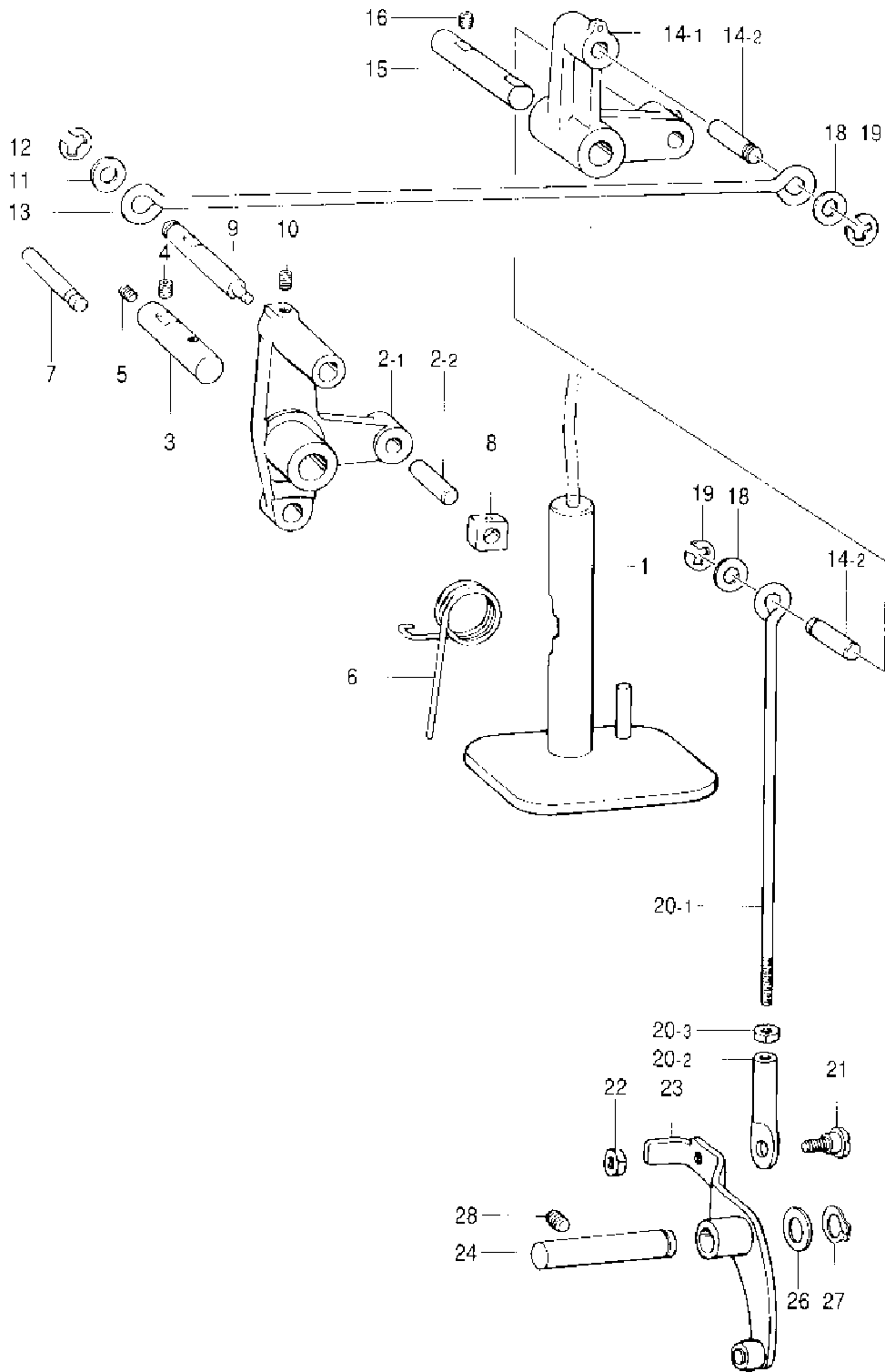

G. Work clamp lifter mechanism

No.	Ret. No.	Description	Qt.
1	B958316009	Presser foot lifter plate assy	1
2	B958313809	Lifter lever assy, ; W – clamp	1
2 – 1	B958312809	Work clamp lifter lever	1
2 – 2	B958366009	Pin	1
3	B958311009	Lifter lever, ; P – bar shaft	1
4	B096340488	Set screw, socket SM5.95	1
5	B097340498	Set screw, (CP) SM5.95	1
6	B95820809	Spring	1
7	B958209009	Spring hook pin	1
8	B908470009	Slide block, ; N – bar guide	1
9	B958208009	Lifter rod shaft, ; P – bar (A)	1
10	B096340488	Set screw, socket SM5.95	1
11	B085020978	Washer, plain S 8	1
12	B062040768	Retaining ring, E6	1
13	B958207009	Lifter rod, A ; P – bar	1
14 – 1	B958205909	Connecting lever	1
14 – 2	B958204909	Connecting lever shaft, B	2
15	B952424009	Lifting lever shaft	1
16	B096340488	Set screw, socket SM5.95	1
18	B085020978	Washer, plain S 8	2
19	B062040768	Retaining ring, E6	2
20	B958202909	Adjust rod assy	1
20 – 1	B956778009	Presser bar lifter adjust rod	1
20 – 2	B956777009	Presser bar lifter adj. joint	1
20 – 3	B950554009	Nut, SM6.35	1
21	B969527909	Shoulder screw, SM6.35	1
22	B950554009	Nut, SM6.35	1
23	B958299009	Connecting lever assy	1
24	B952423009	Driving shaft	1
26	B968482009	Spacer	1
27	B062990968	Retaining ring, external C11	1
28	B096340488	Set screw, socket SM5.95	1

H. Vertical shaft mechanism

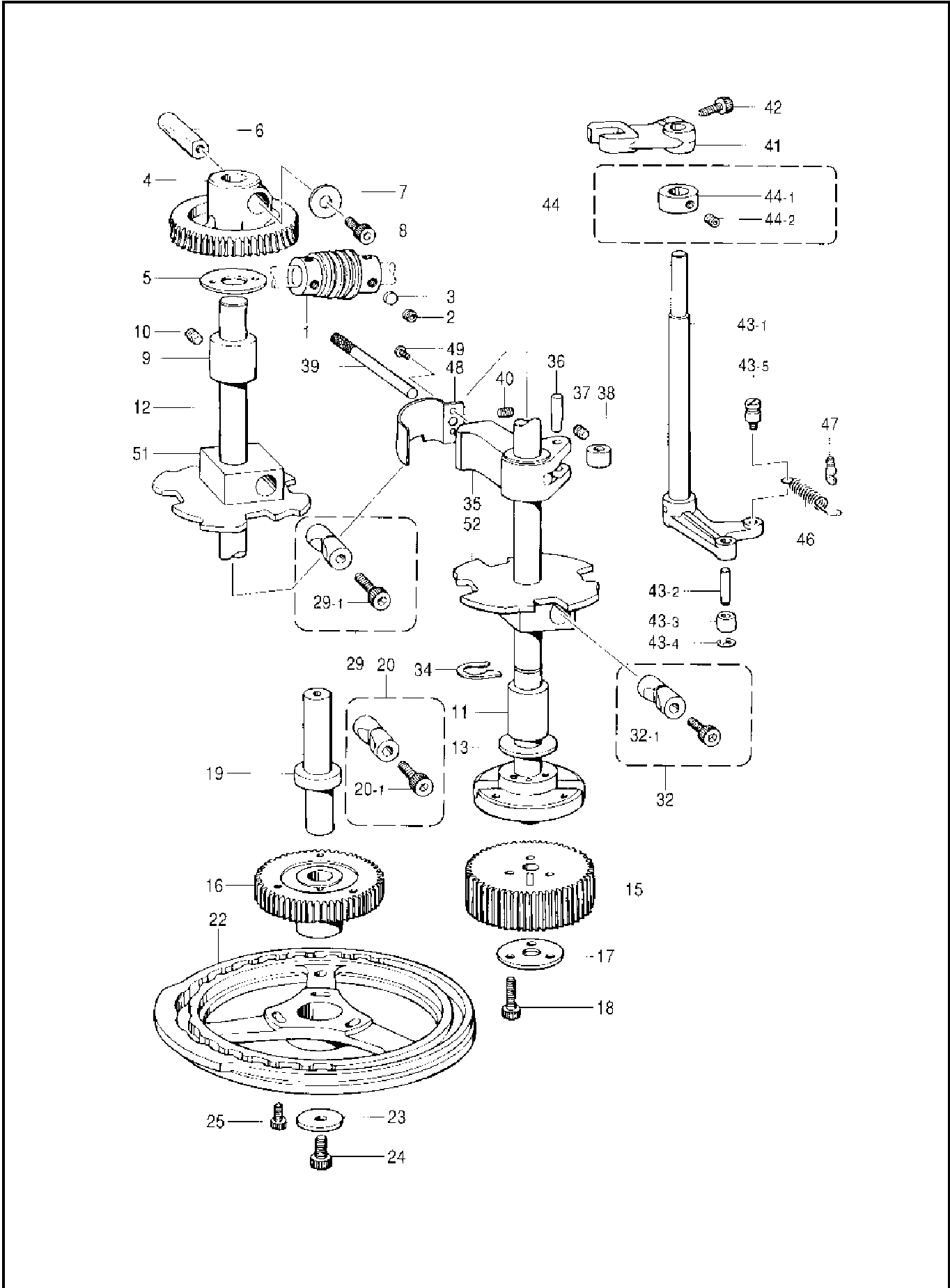

H. Vertical shaft mechanism

No.	Ret. No.	Description	Qty.
1	BX73799009	Worm	1
2	B958392009	Set screw, socket SM5.95 x 5	6
3	B963959000	Washer	1
4	B958302000	Worm wheel	1
5	B958397009	Thrust washer	1
6	B958301000	Sleeve	1
7	B958390009	Washer	1
8	B092048888	Bolt, socket M6 x 22	1
9	B951133900	Vertical shaft bush (U)	1
10	B096340488	Set screw, socket SM5.95	1
11	B951132009	Vertical shaft bush (L)	1
12	B951131009	Vertical shaft assy	1
13	B951126009	Thrust washer 40	1
15	*	Change gear	1
16	*	Change gear	1
17	B937906009	Washer	1
18	B092048888	Bolt, socket M6 x 22	3
19	B958386009	Tack length feed cam shaft	1
20	BX01978059	Pinch sleeve assy	1
20 - 1	B092047088	Bolt, socket M6 x 30	1
22	*	Feed cam	1
23	B958382009	Thrust washer 8	1
24	B959947009	Bolt, socket M8 x 15	1
25	BX72776009	Bolt assy (6 x 22DB)	3
29	BX01978059	Pinch sleeve assy	1
29 - 1	B092047088	Bolt, socket M6 x 30	1
32	BX01978059	Pinch sleeve assy	1
32 - 1	B092047088	Bolt, socket M6 x 30	1
34	B958387009	Stop ring	1
35	B958379909	Roller holder	1
36	B958378009	Roller shaft	1
37	B097390398	Set screw, (CP) SM4.76	1
38	B958196009	Roller	1
39	B958377009	Emergency stop lever	1
40	B097390398	Set screw, (CP) SM4.76	1
41	B958376009	Roller holder lever	1
42	B092049488	Bolt, socket M6 x 16	1
43	B958375909	Roller holder cam lever assy	1
43 - 1	B957778009	Roller holder cam lever shaft assy	1
43 - 2	B958371009	Roller shaft	1
43 - 3	B957915009	Vertical feed crank roller	1
43 - 4	B062060768	Retaining ring, E4	1
43 - 5	B955773009	Spring hook	1
44	BX89355009	Set screw collar assy	1
44 - 1	B990083009	Set screw collar	1
44 - 2	B096340488	Set screw, socket SM5.95	2
46	B955774009	Spring, extension	1
47	B969776009	Spring hook	1
48	B957969009	Roller holder cover	1
49	B048430698	Screw, pan SM3.57 - 40 x 4	2
51	BX03297009	Clutch cam SP	1
52	BX03296009	Knife cam (SP)	1

J. Power lift mechanism

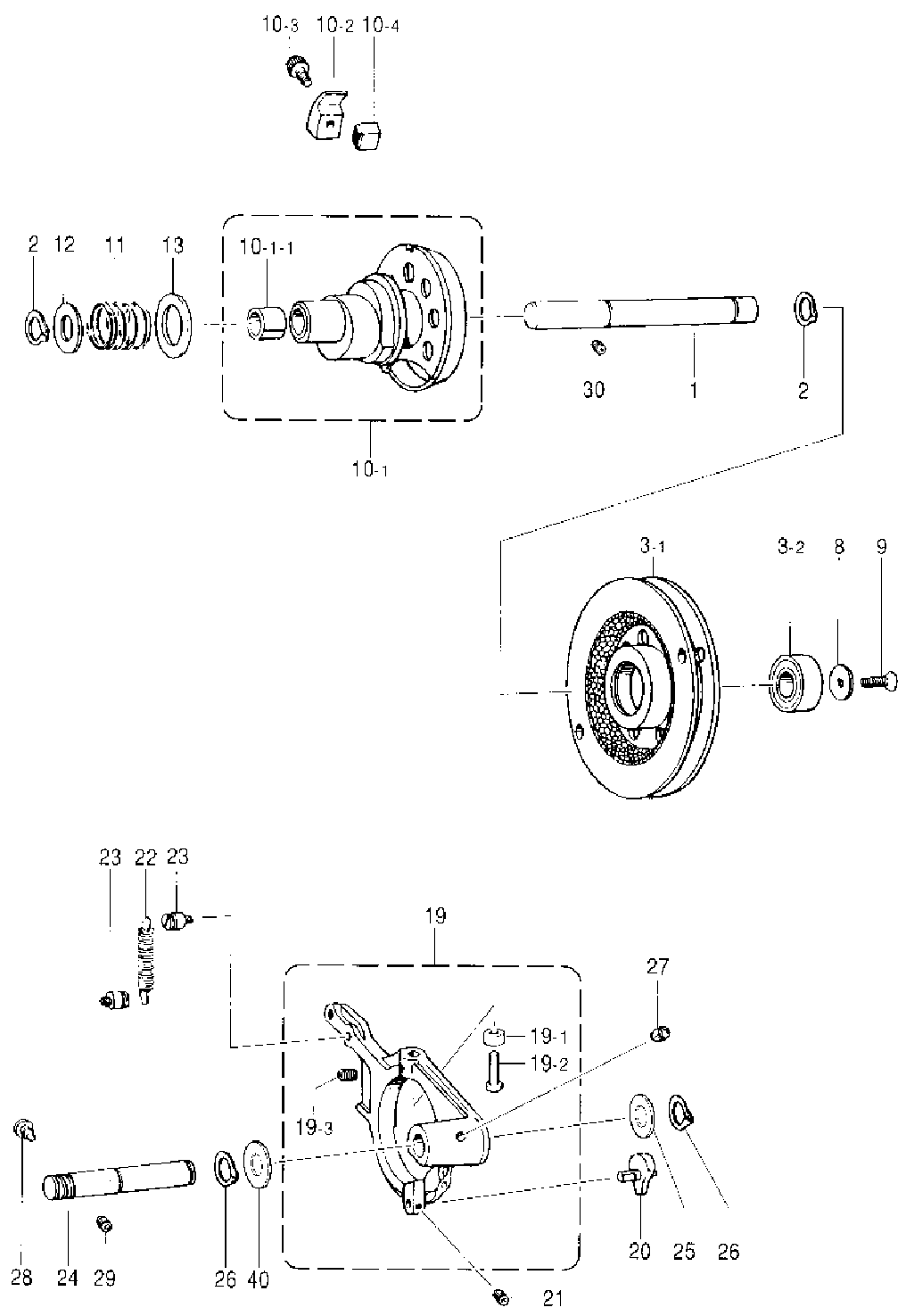

J. Power lift mechanism

No.	Ret. No.	Description	Qty.
1	B959182009	Power pulley shaft	1
2	B062930968	Retaining ring, external C17	2
3	B954174809	Power pulley assy	1
3-1	B959170709	Power pulley assy	1
3-2	B038400740	Ball bearing, 6003W	1
8	B959178009	Bearing cover	1
9	B903879008	Screw, flat SM4. 76	1
10	*	Power cam set	1
10-1	*	Power cam assy	1
10-1-1	BX73789000	Bush	2
10-2	B959160009	Power cam stopper (A)	1
10-3	B092040288	Bolt, socket M6 x8	1
10-4	B959169709	Power cam stopper assy, B	1
11	B959174009	Spring	1
12	B959173009	Thrust washer 17	1
13	B959172009	Washer	1
19	B959166009	Clutch actuating lever assy	1
19-1	B959163909	Roller, 11	2
19-2	B959162009	Roller shaft	2
19-3	B096340488	Set screw, socket SM5. 95	2
20	B959161009	Roller shaft assy	1
21	B096340488	Set screw, socket SM5. 95	1
22	B959159009	Spring, extension	1
23	B969638008	Spring hook	2
24	BX78283009	Clutch actuating lever shaft	1
25	B959157009	Washer, thrust 16	1
26	B062940968	Retaining ring, external C16	2
27	B903961009	Felt	1
28	B959156009	Screw	1
29	B096289088	Set screw, socket (CP) SM7. 94	1
30	B096340488	Set screw, socket SM5. 95	1
40	B950804008	Washer, plain 16	1

K. Lower shaft mechanism

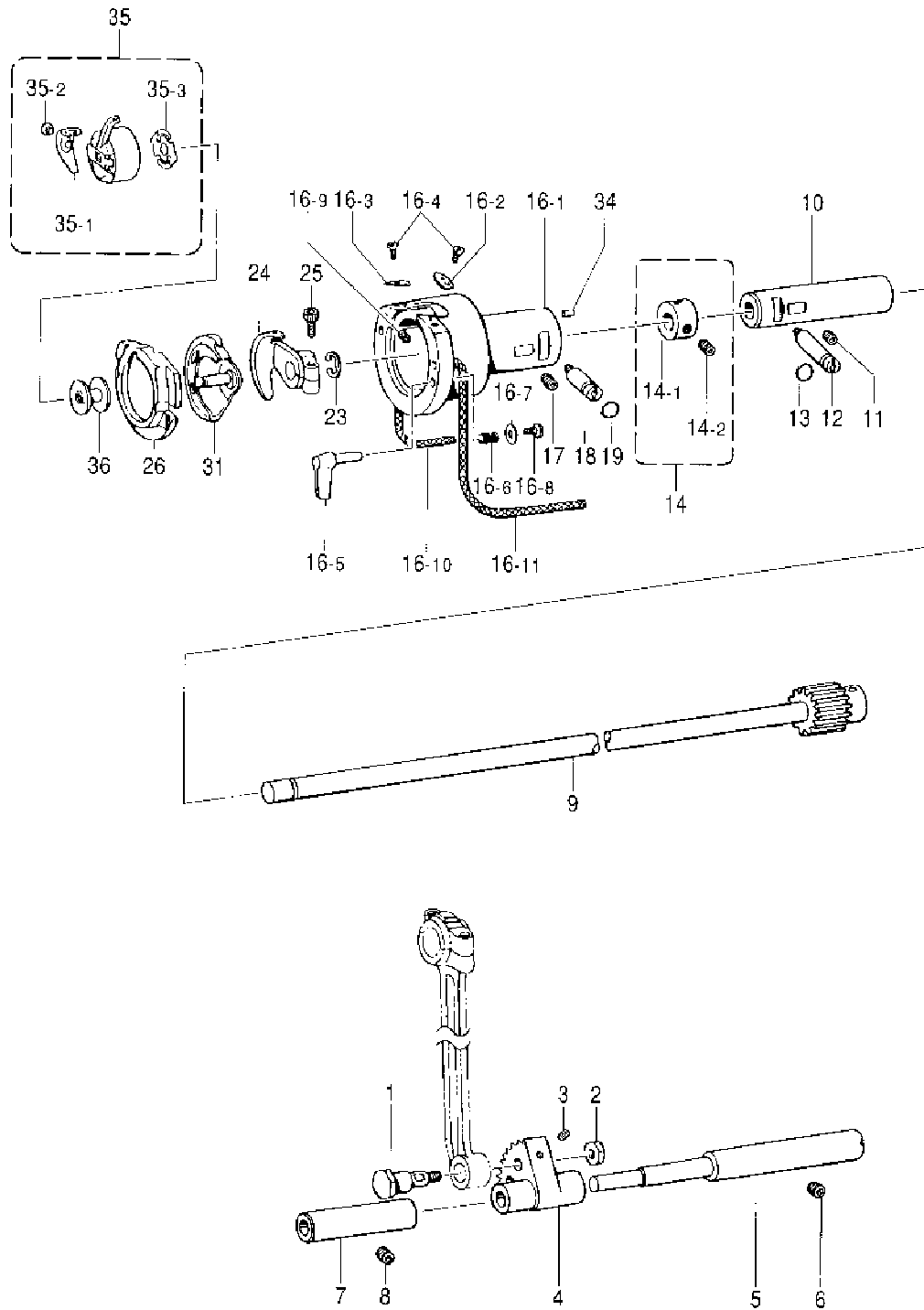

K. Lower shaft mechanism

No.	Ret. No.	Description	Qty.
1	B969324009	Shoulder screw, ; crank rod	1
2	B900010006	Nut, SM7. 14	1
3	B096420488	Set screw, socket (CP) SM4. 37	1
4	B958865909	Rocker gear	1
5	B958864909	Rocker gear shaft	1
6	B096340488	Set screw, socket SM5. 95	1
7	B958863009	Rock shaft bush	1
8	B096340488	Set screw, socket SM5. 95	1
9	B958919909	Lower shaft assy	1
10	B958860009	Lower shaft bush	1
11	B096340488	Set screw, socket SM5. 95	1
12	B958432809	Adjusting stud	1
13	B029007430	O ring, PW3	1
14	BX07306008	Set screw collar assy	1
14 - 1	B990615009	Set screw collar	1
14 - 2	B096330488	Set screw, socket (CP) SM6. 35	2
16	BX00783709	Shuttle race base assy	1
16 - 1	B958433009	Shuttle race base	1
16 - 2	B958431009	Shuttle race thread guide (R)	1
16 - 3	B958420009	Shuttle race thread guide (L)	1
16 - 4	B048440698	Screw, pan SM3. 18 - 40 x 4	2
16 - 5	B958427909	Setting claw, S - race body	2
16 - 6	B958426909	Spring, compression	2
16 - 7	B608223009	Washer, 3. 2	2
16 - 8	B048440398	Screw, pan SM3. 18 - 40 x 7	2
16 - 9	B957050000	Felt, ; S - race base	2
16 - 10	B955621000	Wick (L = 270)	1
16 - 11	BX00600000	Wick 2. 5 x 220	1
17	B096340488	Set screw, socket SM5. 95	1
18	B158432809	Adjusting stud	1
19	B029007430	O ring, PW3	1
23	B062020768	Retaining ring, E8	1
24	B958429809	Driver	1
25	B092509688	Bolt, socket M5 x 14	1
26	*	Shuttle race body	1
31	*	Shuttle hook assy W/box	1
34	B980672009	Pin	1
35	B951490709	Bobbin case assy, A	1
35 - 1	B956771909	Tension spring	1
35 - 2	B956769009	Screw	1
35 - 3	B951498009	Spring, anti - spin	1
36	B951497059	Bobbin	1

L. Lubrication

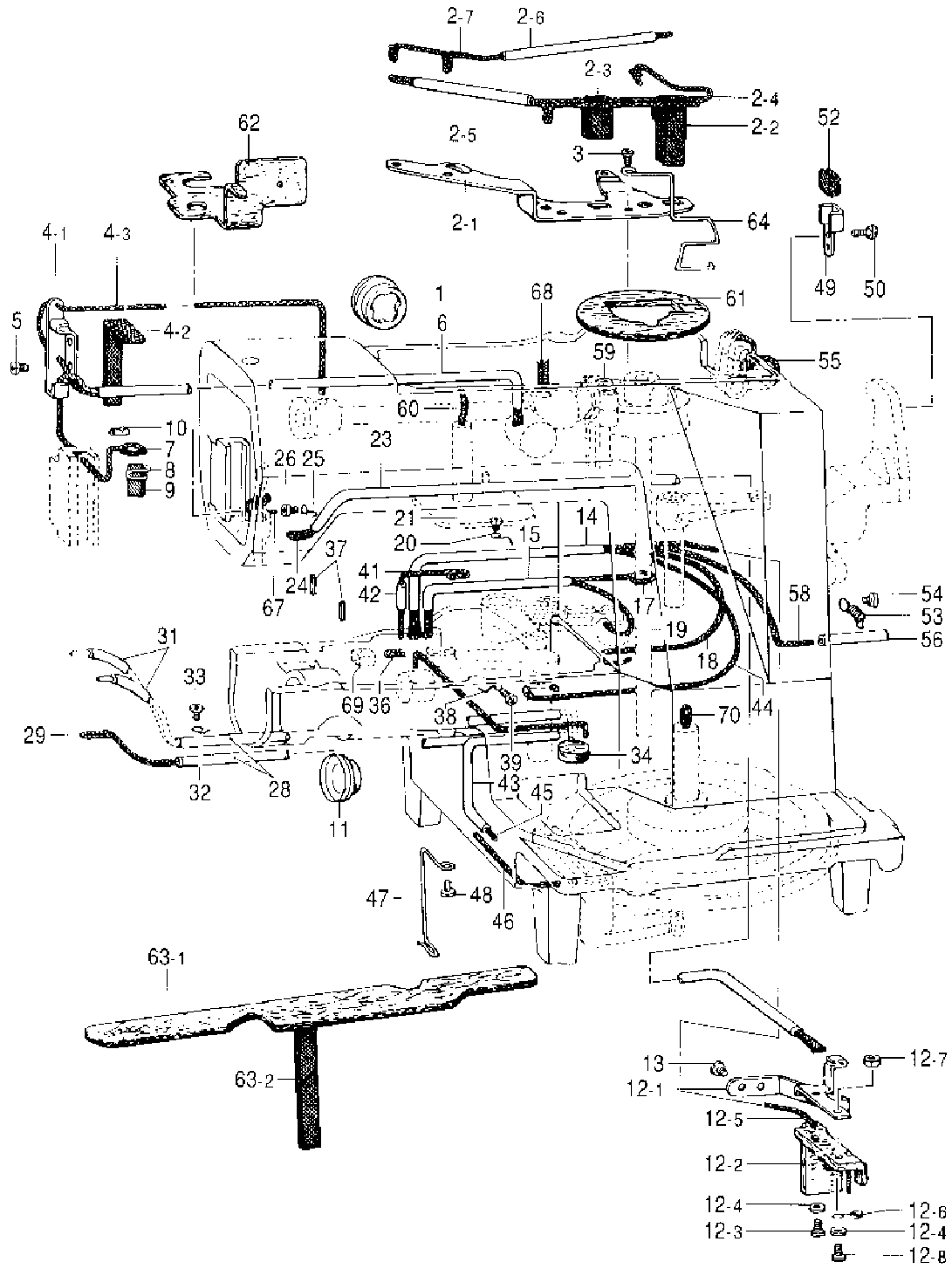

L. Lubrication

No.	Ret. No.	Description	Qt.
1	B958162009	Oil window	1
2	B958161009	Wick support assy	1
2-1	B958150009	Wick support	1
2-2	B958159009	Felt	1
2-3	BX69897000	Felt, lubrication	1
2-4	B957192009	Wick, 6 x 6 L = 660	1
2-5	B980687000	Oil tube	1
2-6	B963365000	Oil tube (L)	1
2-7	B957191009	Wick, 6 x 6 L = 370	1
3	B048420298	Screw, pan SM4. 37 - 40 x 8	2
4	B958152009	Wick support assy	1
4-1	B958151009	Wick support	1
4-2	B958155009	Flat wick, L = 210	1
4-3	B958154009	Wick, 4 x 4 L = 500	1
5	B048420498	Screw, pan SM4. 37 - 40 x 8	1
6	B966416009	Oil tube	1
7	B958154009	Wick, 4 x 4 L = 500	1
8	B958148009	Wick support	1
9	B958140009	Flat wick, L = 40	1
10	B906543009	Wick support	1
11	B958162009	Oil window	1
12	B958149009	Felt support assy	1
12-1	B958144009	Felt support	1
12-2	B958143009	Felt	1
12-3	B048430298	Screw, pan SM3. 57 - 40 x 8	2
12-4	B085750778	Washer, plain L 3. 5	3
12-5	B958147009	Wick 4 x 4 (L = 600)	1
12-6	B969418009	Tube support, C	1
12-7	B089430808	Nut, 2 SM3. 57	1
12-8	B048439698	Screw, pan SM3. 57 - 40 x 14	1
13	B048430498	Screw, pan SM3. 57 - 40 x 6	2
14	B962187000	Oil tube	1
15	B963365000	Oil tube (L)	1
17	B958146009	Wick 6 x 6 (L = 310)	1
18	B958145009	Wick 4 x 4 (L = 400)	1
19	B958146009	Wick 6 x 6 (L = 310)	1
20	B958141006	Cord support	1
21	B048430598	Screw, pan SM3. 57 - 40 x 5	1
23	B964735000	Oil tube	1
24	B958118009	Flat wick (L = 760)	1
25	B993950009	Cord holder	1
26	B048430598	Screw, pan SM3. 57 - 40 x 5	1
28	B960687000	Oil tube	2
29	B958139009	Wick 4 x 4 (L = 480)	1
31	B998441009	Oil tube	2
32	B958141009	Cord support	1
33	B048430598	Screw, pan SM3. 57 - 40 x 5	1
34	B997004009	Felt	1
36	B958137009	Wick, 4 x 4 L = 170	1
37	B063859460	Pin, spring ril AW2. 5	2
38	B993950009	Cord holder	1
39	B048430598	Screw, pan SM3. 57 - 40 x 5	1
41	B958136009	Wick, 4 x 4 L = 350	1
42	B998441009	Oil tube	1
43	B963365000	Oil tube (L)	1
44	B957188009	Wick, 4 x 4 L = 340	1
45	B958157009	Wick 6 x 6 (L = 360)	1
46	B958125009	Wick 4 x 4 (L = 120)	1
47	B957347009	Wick support	1
48	B048430598	Screw, pan SM3. 57 - 40 x 5	1

L. Lubrication

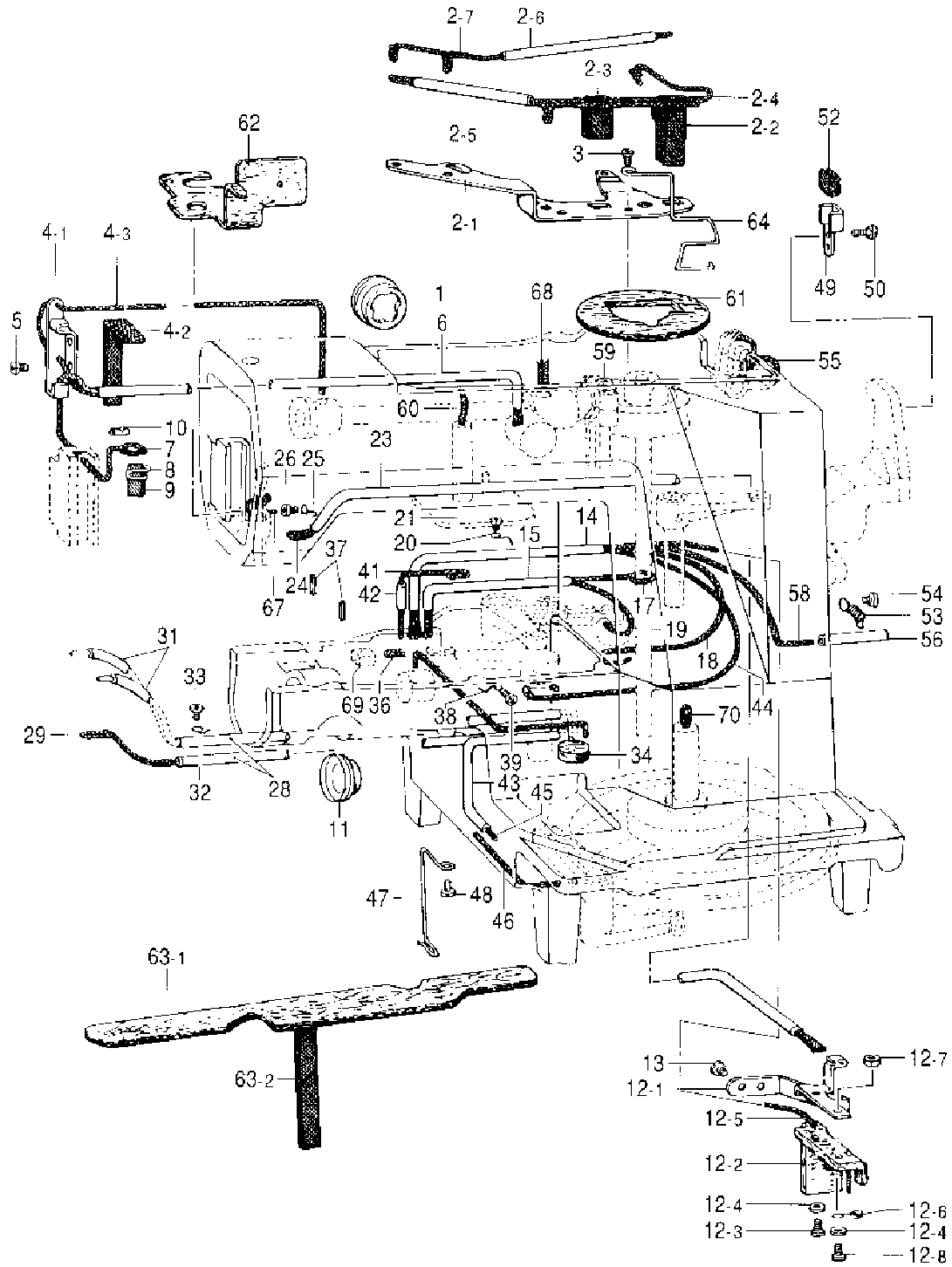

L. Lubrication

No.	Ret. No.	Description	Qty.
49	B958134009	Wick support	1
50	B048430598	Screw, pan SM3. 57 - 40 x 5	2
52	B958133009	Flat wick (L = 50)	1
53	B958132009	Tube support	1
54	B048420298	Screw, pan SM4. 37 - 40 x 8	1
55	B957183009	Wick, 6 x 6 L = 180	1
56	B998441009	Oil tube	1
58	B957188009	Wick, 4 x 4 L = 340	1
59	B903961009	Felt	1
60	B958142009	Wick 4 x 4 (L = 100)	1
61	B957581909	Felt	1
62	B957570009	Felt	1
63 - 1	B957579009	Bed (L) felt	1
63 - 2	B957548009	Flat wick, L = 160	1
64	B957582009	Felt support	1
67	B958137009	Wick, 4 x 4 L = 170	1
68	B957185009	Wick, 4 x 4 L = 30	1
69	B957184009	Wick, L = 10	1
70	B958120009	Wick 6 x 6 (L = 150)	1

M. Threading mechanism

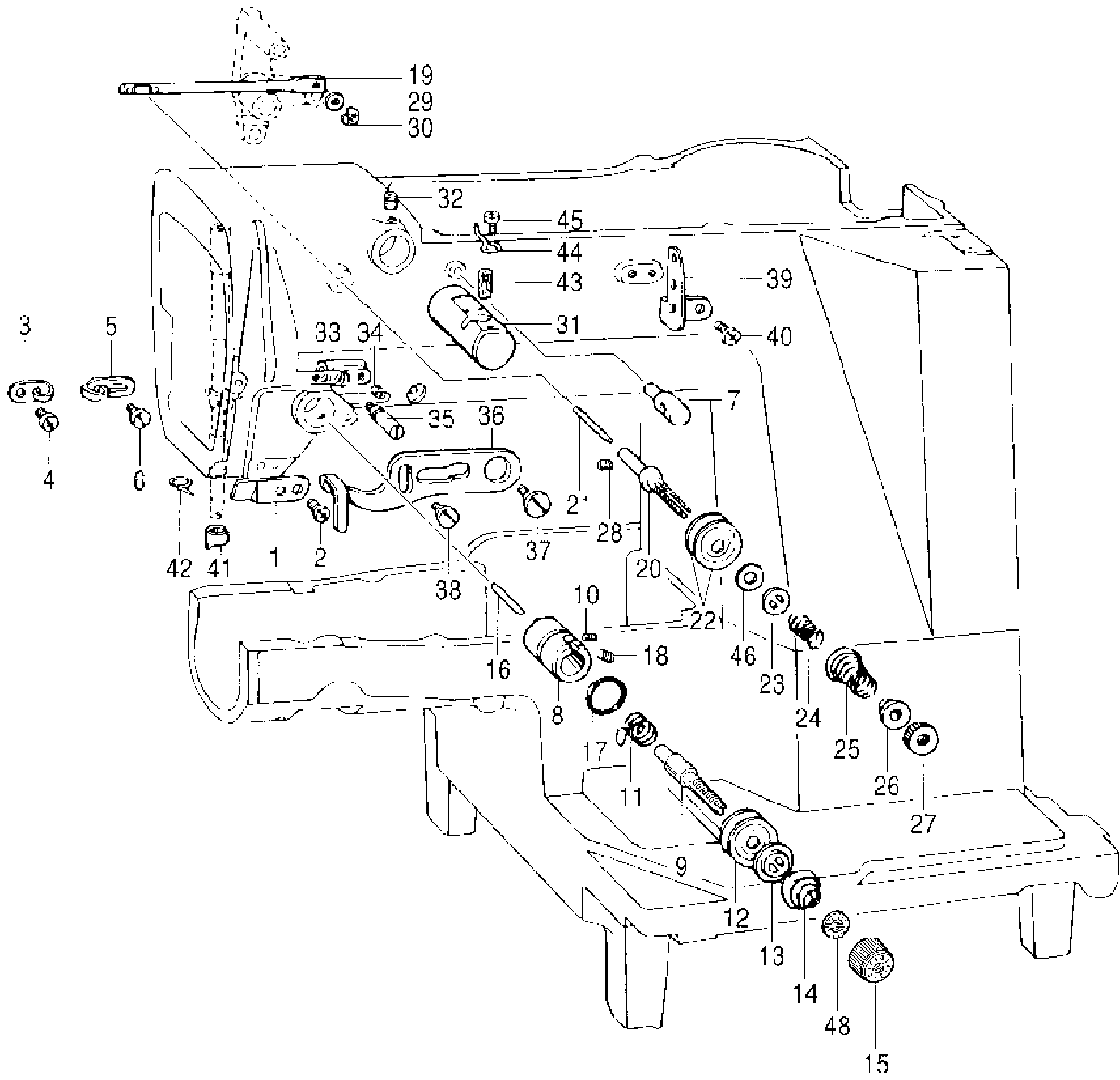

M. Threading mechanism

No.	Ret. No.	Description	Qt.
1	B958241009	Thread guide, ; arm	1
2	B048390498	Screw, pan SM4. 76 – 32 × 6	1
3	B958230009	Thread guide, ; arm	1
4	B048430498	Screw, pan SM3. 57 – 40 × 6	1
5	B997794009	Thread guide	1
6	B040430498	Screw, bind SM3. 57 – 40 × 6	1
7	B957061009	Upper thread guide stud	1
8	B958238009	Tension bracket	1
9	B994188009	Tension stud	1
10	B900608006	Set screw, SM3. 57	1
11	*	Thread take – up spring	1
12	B965664009	Disc, tension	2
13	B951205009	Disc presser, ; tension	1
14	*	Spring, tension	1
15	BX79078009	Tension nut	1
16	B958237009	Tension release pin	1
17	B996816009	O ring	1
18	BX90641009	Set screw, socket SM5. 95	1
19	B958236009	Sub tension release bar	1
20	B958235009	Sub tension stud	1
21	B958234009	Pin	1
22	B965664009	Disc, tension	2
23	B958233009	Tension disc washer	1
24	B958232009	Spring	1
25	B958231909	Sub tension spring	1
26	B958220009	Spring holder	1
27	B900974009	Nut, tension	1
28	B096420688	Set screw, socket (CP) SM4. 37	1
29	B964756009	Washer, plain 5	1
30	B062060788	Retaining ring, E4	1
31	B958229009	Needle cooler assy	1
32	B097340498	Set screw, (CP) SM5. 95	1
33	B958224009	Thread take – up guide	1
34	B096420688	Set screw, socket (CP) SM4. 37	1
35	B958223009	Thread take – up lever guide stud	1
36	BX75393009	Thread take – up lever	1
37	BX03730908	Shoulder screw, SM5. 95	1
38	B995033007	Stud screw 4. 76	1
39	B958221009	Thread retainer	1
40	B048430498	Screw, pan SM3. 57 – 40 × 6	2
41	B958210009	Thread guide, A ; N – bar	1
42	B958219909	Thread guide, ; N – bar bush	1
43	B958227000	Felt, 8 × 15. 5	1
44	B958226009	Thread guide, ; N – cooler	1
45	B048430698	Screw, pan SM3. 57 – 40 × 4	1
46	B957972009	Washer, plain 6. 5	1
48	BX98669009	Washer	1

N. Bobbin winder mechanism

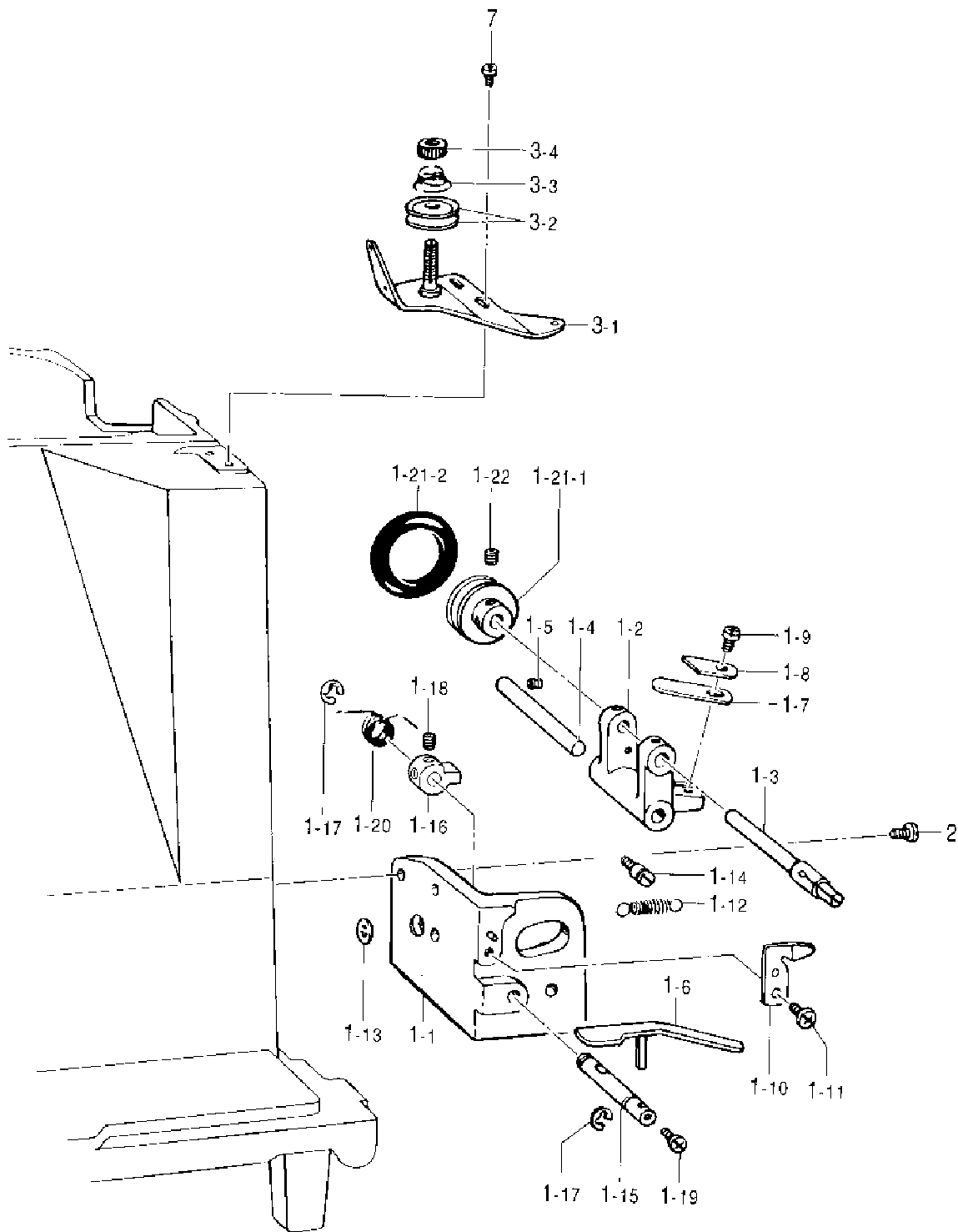

N. Bobbin winder mechanism

No.	Ret. No.	Description	Qty.
1	B958128801	Bobbin winder assy	1
1-1	B958127901	Bobbin winder bracket	1
1-2	B958126058	Bobbin winder lever	1
1-3	B958177009	Bobbin winder shaft	1
1-4	B958176009	Bobbin winder lever shaft	1
1-5	B908394006	Set screw, SM4. 37	1
1-6	B958175009	Bobbin presser	1
1-7	B958174009	Spring, plate	1
1-8	B958173009	Washer	1
1-9	B048430398	Screw, pan SM3. 57 - 40 x 7	1
1-10	B958172009	Knife	1
1-11	B048420398	Screw, pan SM4. 37 - 40 x 7	1
1-12	B958171009	Spring	1
1-13	B995972009	Spring hook	1
1-14	B989550009	Spring hook	1
1-15	B958160009	Bobbin winder claw stud	1
1-16	BX01442009	Bobbin winder claw	1
1-17	B062050768	Retaining ring, E5	2
1-18	B096420688	Set screw, socket (CP) SM4. 37	2
1-19	B048430398	Screw, pan SM3. 57 - 40 x 7	1
1-20	B958169009	Twist spring	1
1-21-1	B956582009	Wheel, ; B - winder	1
1-21-2	B980662009	Bobbin winder rubber band	1
1-22	B908394006	Set screw, SM4. 37	2
2	B048349698	Screw, pan SM5. 95 - 28 x 14	2
3	BX09700001	Lower thread tension assy	1
3-1	B958165009	Lower thread tension bracket assy	1
3-2	B965664009	Disc, tension	2
3-3	B906585009	Spring, tension ; M	1
3-4	B902845001	Tension nut	1
7	B048420298	Screw, pan SM4. 37 - 40 x 8	2

P. Thread trimmer mechanism

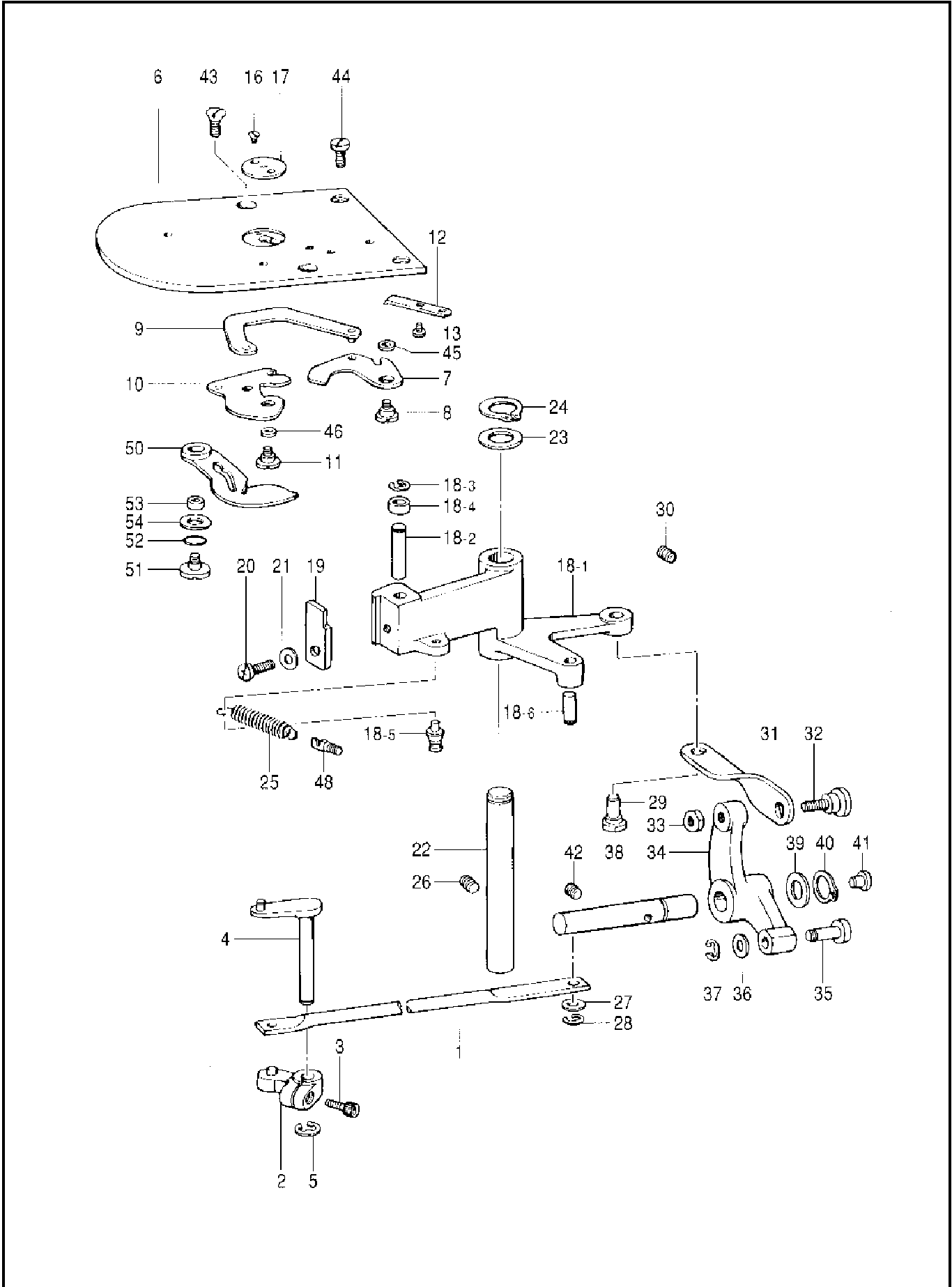

P. Thread trimmer mechanism

No.	Ret. No.	Description	Qty.
1	B958218009	Thread trimmer connecting rod	1
2	B958214009	Thread trimmer arm assy, A	1
3	B092429088	Bolt, socket SM4. 37 × 10	1
4	B958217909	Thread trimmer arm (B)	1
5	B062060768	Retaining ring, E5	1
6	B958115009	Needle plate, S	1
7	B958129009	Knife arm (C)	1
8	B957888009	Screw, SM4. 37	1
9	B958213809	Thread trimmer connecting rod	1
10	B958109009	Movable knife assy	1
11	B958106009	Screw, SM4. 37	1
12	B958105009	Fixed knife	1
13	B999960008	Screw, SM2. 38	2
16	B900740007	Screw, flat SM2. 38	2
17	*	Needle hole plate	1
18 - 1	B958198009	Thread trimmer cam lever	1
18 - 2	B958197009	Roller shaft	1
18 - 3	B062060768	Retaining ring, E4	1
18 - 4	B958196009	Roller	1
18 - 5	B956321009	Spring hook	1
18 - 6	B958191009	Pin	1
19	B958195009	Thread trimmer cam lever claw	1
20	B048349698	Screw, pan SM5. 95 - 28 × 14	1
21	B085040978	Washer, plain S 6	1
22	B958194009	Thread trimmer cam lever shaft	1
23	B958193009	Washer	1
24	B062980968	Retaining ring, external C12	1
25	B956322009	Spring	1
26	B096340488	Set screw, socket SM5. 95	1
27	B964756009	Washer, plain 5	1
28	B062060768	Retaining ring, E4	1
29	B958180009	Stud	1
30	B096340488	Set screw, socket SM5. 95	1
31	B958189009	Thread trimmer link	1
32	B959103009	Stud screw 5. 95	1
33	B950557009	Nut, SM5. 95	1
34	B958188009	Thread trimmer lever	1
35	B958187009	Thread trimmer roller	1
36	B998642009	Washer	1
37	B062060768	Retaining ring, E5	1
38	B957628009	Driving shaft	1
39	B968482009	Spacer	1
40	B062990968	Retaining ring, external C11	1
41	B999245001	Cap, 6	1
42	B096340488	Set screw, socket SM5. 95	1
43	B900078006	Screw, flat SM4. 37 - 40 × 8	2
44	BX99866009	Screw, SM4. 37	2
45	B957880009	Knife arm collar, C	1
46	B957891009	Collar, ; movable knife	1
48	B969776009	Spring hook	1
50	B958104909	Lower thread retainer (A)	1
51	B957512009	Screw 4. 37	1
52	B029002030	O ring, P8	1
53	B957513009	Retainer collar, ; L - thread	1
54	B957514009	Washer	1

Q. Thread wiper mechanism

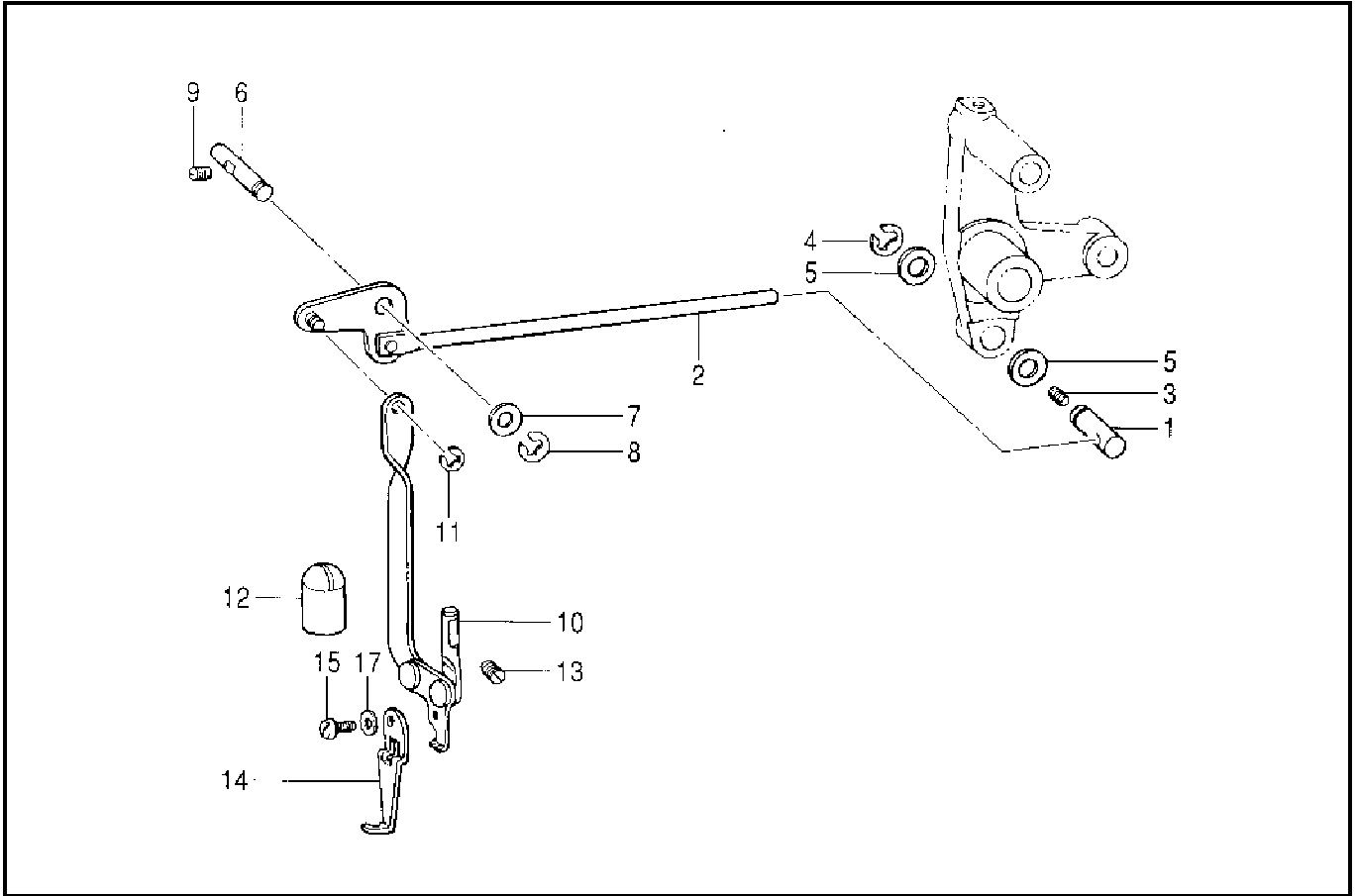

R. Thread nipper mechanism

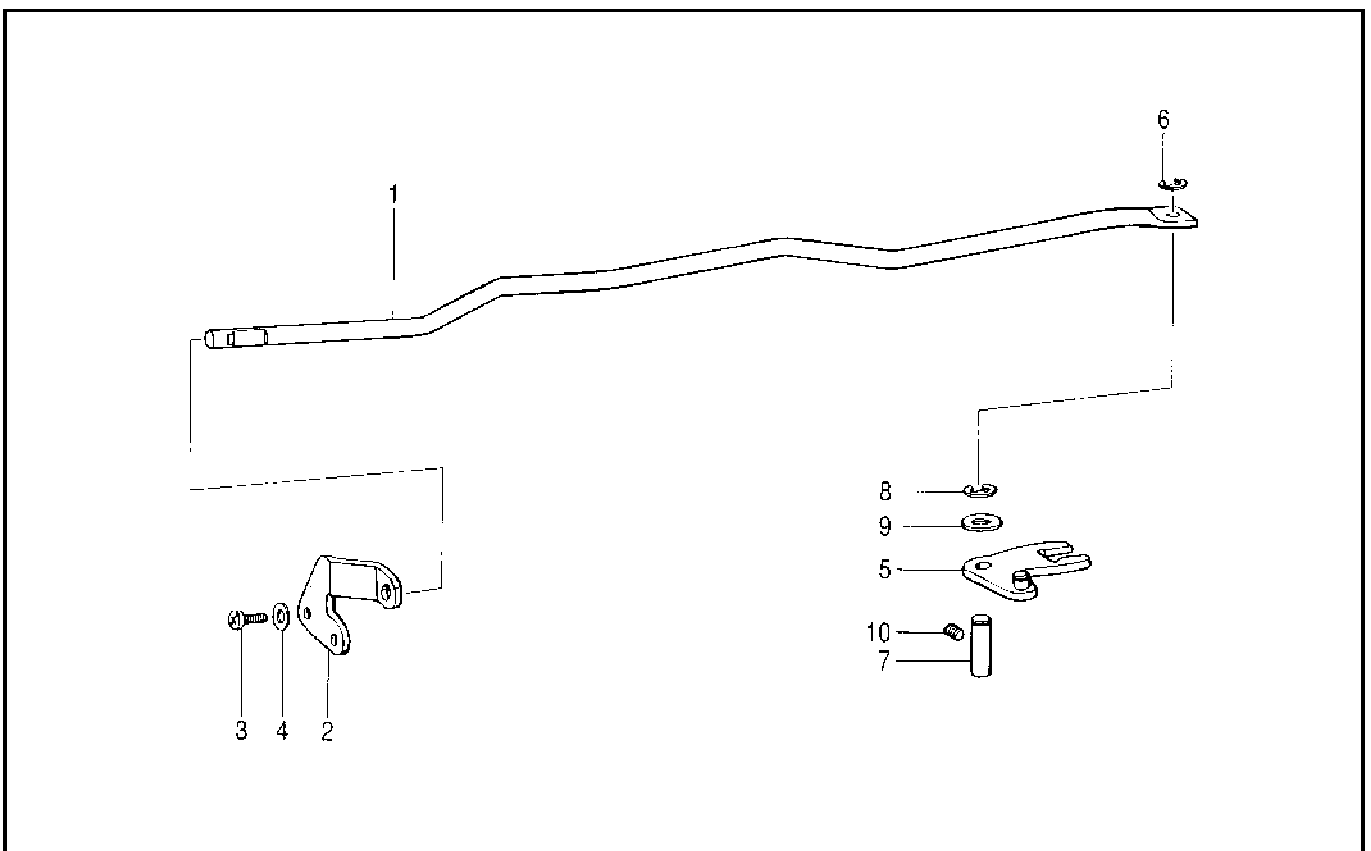

Q. Thread wiper mechanism

No.	Ret. No.	Description	Qt.
1	B958295009	Thread wiper rod shaft	1
2	B958294009	Thread wiper rod assy	1
3	B096420488	Set screw, socket (CP) SM4. 37	1
4	B062040768	Retaining ring, E6	1
5	B994481009	Washer	2
6	B958288909	Shaft, ;T –wiper	1
7	B085330878	Washer, plain M 6. 35	1
8	B062060768	Retaining ring, E4	1
9	B096420488	Set screw, socket (CP) SM4. 37	1
10	B958287009	Thread wiper arm assy	1
11	B062070768	Retaining ring, E3	1
12	B958283009	Oil cap	1
13	B096390588	Set screw, socket (CP) SM4. 76	1
14	B954804009	Thread wiper, A	1
15	B048430598	Screw, pan SM3. 57 – 40 × 5	1
17	B085750978	Washer, plain S 3. 5	1

R. Thread nipper mechanism

No.	Ret. No.	Description	Qt.
1	B958185909	Needle thread release bar	1
2	B958184009	Tension release bar plate	1
3	B048439098	Screw, pan SM3. 57 – 40 × 10	2
4	B085750778	Washer, plain L 3. 5	2
5	B958122009	Upper thread release lever assy	1
6	B062060768	Retaining ring, E4	1
7	B958181009	Needle thread release lever shaft	1
8	B062060768	Retaining ring, E5	1
9	B085330878	Washer, plain M 6. 35	1
10	B096340488	Set screw, socket SM5. 95	1

S. Attachment set

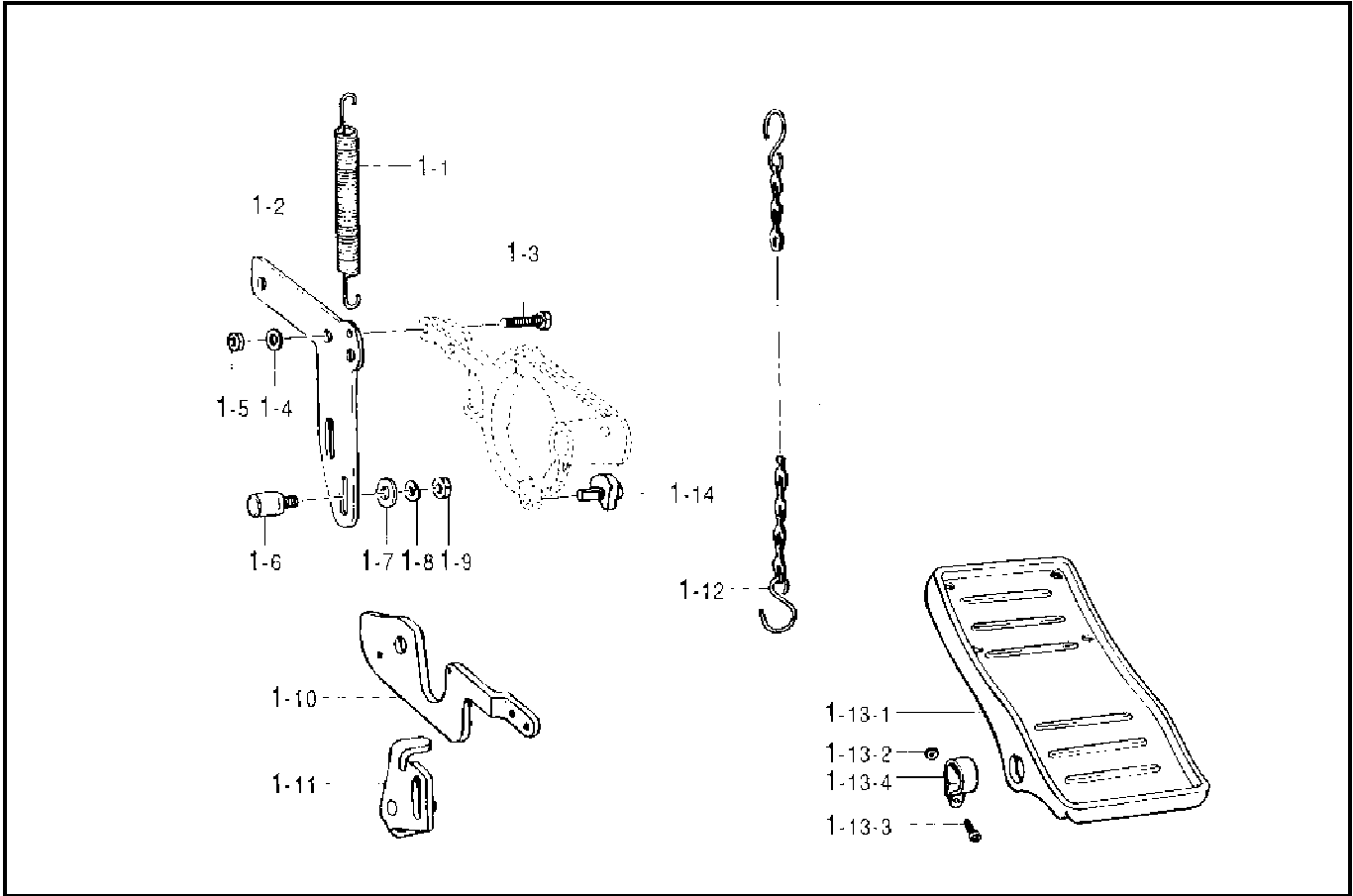

T. Option parts

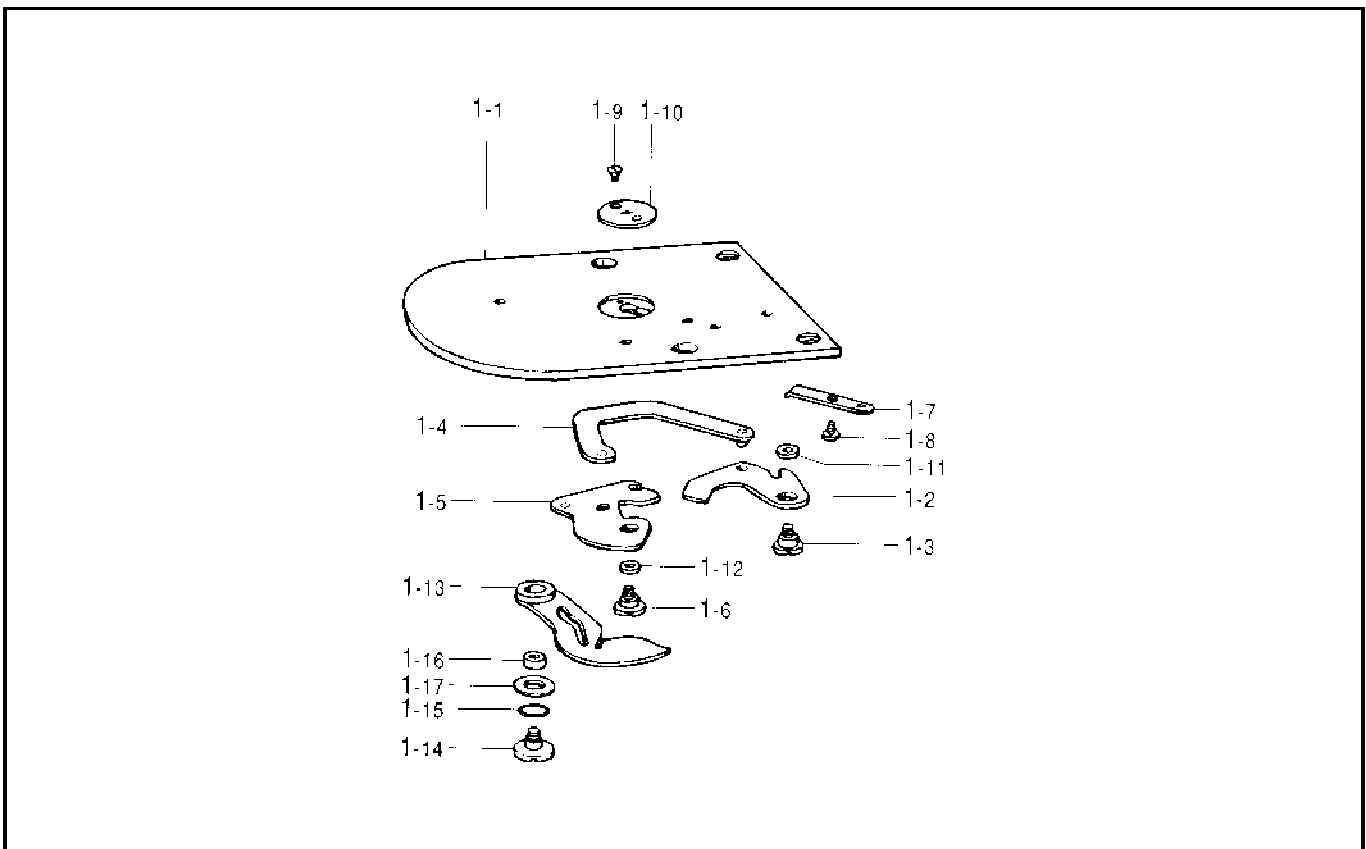

S. Attachment set

No.	Ret. No.	Description	Qt.
1	B956301008	Mechanism two pedals assy	1
1-1	B956658009	Spring	1
1-2	B956662009	Drive lever plate	1
1-3	B093348098	Bolt, SM5. 95 x 20	2
1-4	B085040878	Washer, plain M 6	2
1-5	B950557009	Nut, SM5. 95	2
1-6	B956661009	Stopper	2
1-7	B085020878	Washer, plain M 8	2
1-8	B082020868	Washer, spring 2 - 8	2
1-9	B905298007	Nut, SM7. 94	2
1-10	B956650009	Release drive lever B	1
1-11	B956659909	Starting stopper, B	1
1-12	B961863009	Chain assy	1
1-13	B994925801	Pedal assy	1
1-13-1	B993673901	Foot lifter pedal	1
1-13-2	B089600904	Nut, 1 M4	2
1-13-3	B048609694	Screw, pan M4 x 14	2
1-13-4	B994094009	Pedal stopper	2
1-14	B956429009	Roller shaft assy, B	1

T. Option parts

No.	Ret. No.	Description	Qt.
1	BX92684009	Needle plate assy, S	1
1-1	B958115009	Needle plate, S	1
1-2	B958129009	Knife arm (C)	1
1-3	B957888009	Screw, SM4. 37	1
1-4	B958213809	Thread trimmer connecting rod	1
1-5	B958109009	Movable knife assy	1
1-6	B958106009	Screw, SM4. 37	1
1-7	B958105009	Fixed knife	1
1-8	B999960008	Screw, SM2. 38	2
1-9	B900740007	Screw, flat SM2. 38	2
1-10	B954950009	Needle hole plate, B	1
1-11	B957880009	Knife arm collar, C	1
1-12	B957891009	Collar, ; movable knife	1
1-13	B958104909	Lower thread retainer (A)	1
1-14	B957512009	Screw 4. 37	1
1-15	B029002030	O ring, P8	1
1-16	B957513009	Retainer collar, ; L - thread	1
1-17	B957514009	Washer	1

Z. Accessories

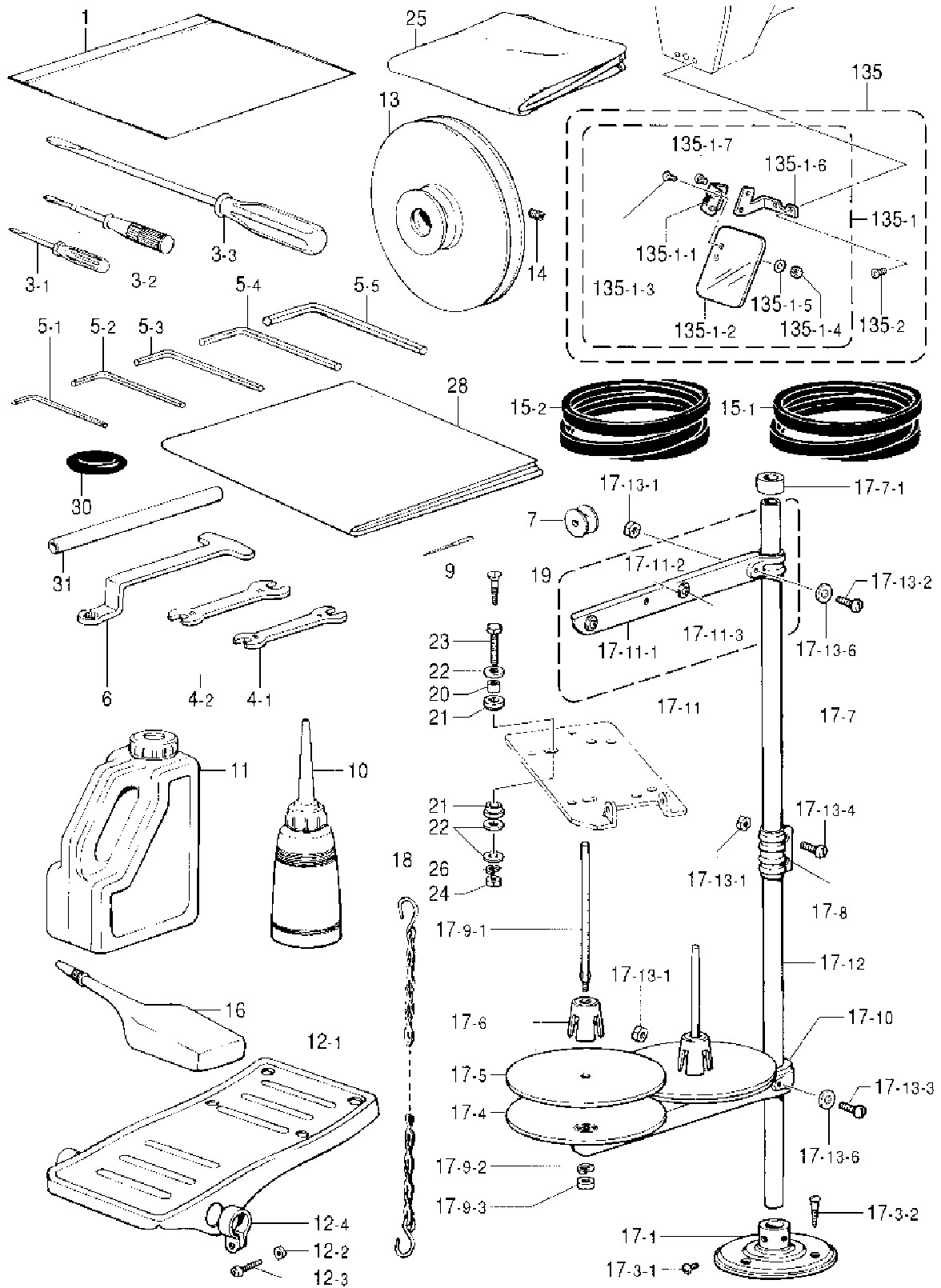

Z. Accessories

No.	Ret. No.	Description	Qt.
1	B988119009	Accessory bag	1
3-1	B988667009	Screw driver, 1.9 x 52	1
3-2	B992273009	Screw driver, 3.4 x 70	1
3-3	B909538909	Screw driver, 5.5 x 190	1
4-1	B900223009	Wrench, 8 x 9	1
4-2	B903320009	Wrench, 10 x 12	1
5-1	B968008009	Hexagonal wrench, 2	1
5-2	B968389009	Allen wrench 3	1
5-3	B992046009	Hexagonal wrench, 4	1
5-4	B950775009	Hexagonal wrench, 5	1
5-5	B995953009	Hexagonal wrench, 6	1
6	B958345009	Offset wrench 10	1
7	B951497059	Bobbin	3
9	*	Needle, DP	4
10	B996627008	Oiler assy	1
11	BX55447009	Oil tank assy	1
12	B994925801	Pedal assy	1
12-1	B993673901	Foot lifter pedal	1
12-2	B089600904	Nut, 1 M4	2
12-3	B048609694	Screw, pan M4 x 14	2
12-4	B994094009	Pedal stopper	2
13	*	Motor pulley	1
14	B096340488	Set screw, socket SM5. 95	2
15-1	B028906219	Belt, VM48	1
15-2	*	Belt, VM	1
16	*	Silicone oil	1
17	BX08349701	Cotton stand assy, 2	1
17-1	B950921901	Cotton stand bracket	1
17-3	BX08337009	C - stand bracket & screw set	1
17-3-1	B048040204	Screw, pan M6 x 8	2
17-3-2	B079668804	Wood screw, round M4. 5 x 22	3
17-4	BX59827009	Spool stand base	2
17-5	B950928000	Spool mat	2
17-6	BX59828009	Spool cushion	2
17-7	BX60471009	Column pipe W/cap	1
17-7-1	B950936000	Column cap	1
17-8	B950937007	Column joint	1
17-9	BX89312009	Spool & screw set	2
17-9-1	B950931008	Spool shaft, B	2
17-9-2	B082050864	Washer, spring 2-5	2
17-9-3	B089500904	Nut, 1 M5	2
17-10	BX08332008	Spool holder, 2	1
17-11	BX08324008	Thread hanger assy, 2	1
17-11-1	BX08323008	Thread hanger, 2	1
17-11-2	B950927000	Thread hanger base	2
17-11-3	B988110009	Thread bush	2
17-12	B950938007	Column pipe	1
17-13	BX60469009	Spool shaft & screw set, A	1
17-13-1	B089500904	Nut, 1 M5	4
17-13-2	B048509604	Screw, pan M5 x 14	1
17-13-3	B048509604	Screw, pan M5 x 14	1
17-13-4	B048509604	Screw, pan M5 x 14	2
17-13-6	B084050974	Washer, plain S 5	2
18	B981863009	Chain assy	1
19	B904070009	Wood screw, flat M6. 2 x 32	4
20	B958247009	Cushion collar	4
21	B958246009	Cushion	8

Z. Accessories

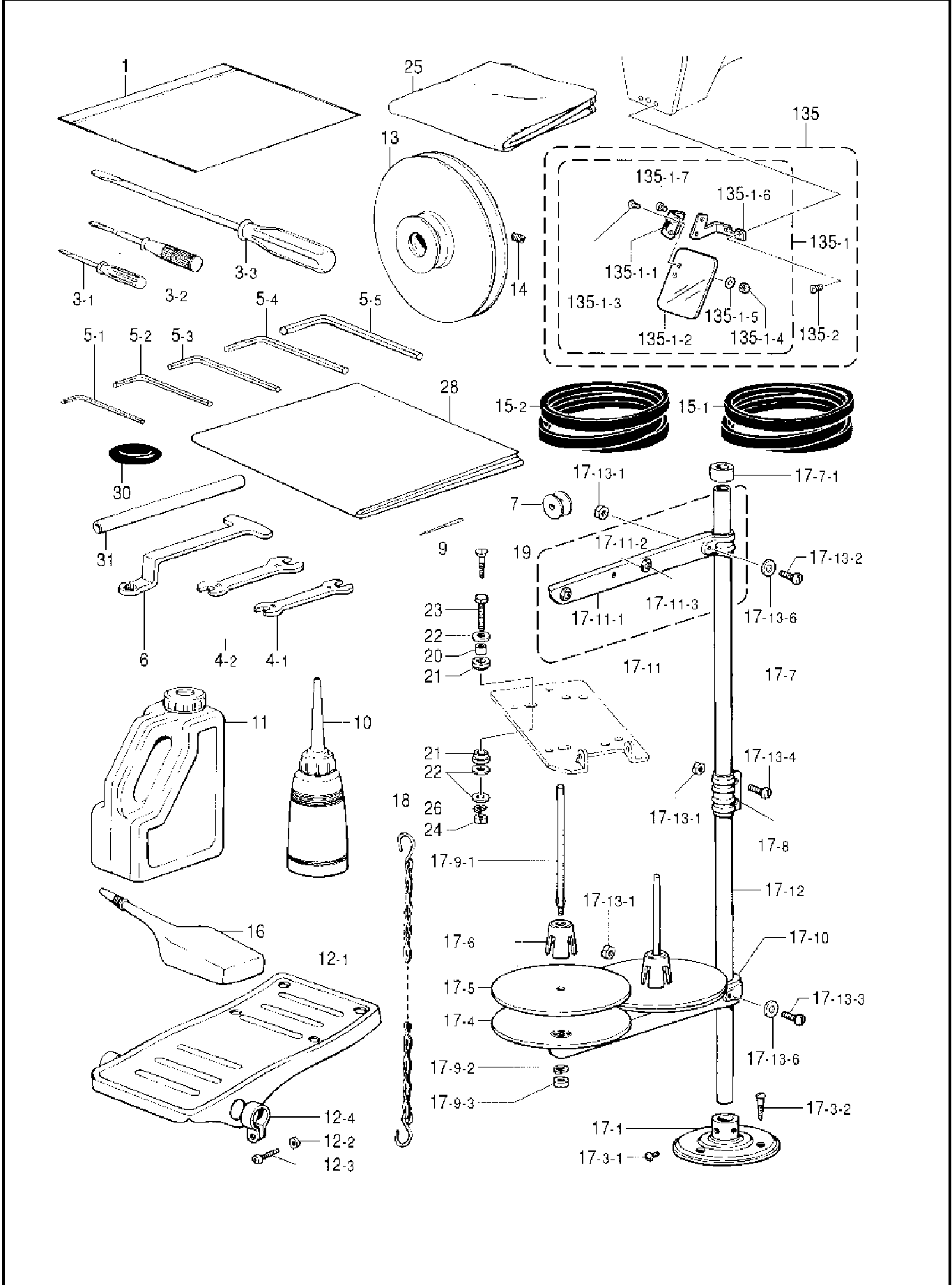

Z. Accessories

No.	Ret. No.	Description	Qty.
22	B085200778	Washer, plain L 7.14	12
23	B093048507	Bolt, M6 x 25	4
24	B089040908	Nut, 1 M6	4
25	B966884009	Head cover	1
26	B082040868	Washer, spring 2-6	4
28	B957536809	Table sheet	1
30	B980862009	Bobbin winder rubber band	1
31	B956340001	Pipe, wrench	1
135	BX50003009	Eye guard set, A	1
135-1	BX66617909	Eye guard assy	1
135-1-1	BX66627009	Hinge assy	1
135-1-2	BX66625009	Eye guard	1
135-1-3	B049440204	Screw, flat SM3. 18-40 x 8	2
135-1-4	B089440908	Nut, 1 SM3. 18	2
135-1-5	B084070878	Washer, plain M 3	2
135-1-6	BX66624909	Eye guard holder, A	1
135-1-7	B048430598	Screw, pan SM3. 57-40 x 5	2
135-2	B048430498	Screw, pan SM3. 57-40 x 6	2

Different parts list

Subclass	Ret. No.	A - 62	C - 27 Z - 9	F - 35	F - 35 - 8	F - 35 - 9	F - 35 - 18	F - 44
	Parts Spec	Label	Needle DP	Presser arm assembly	Work clamp (R)	Work clamp (L)	Spring	Feed plate
- 11	Ordinary clothes	B957054909	B903695094 (DPX5 16#)	B958343501	B958333009	B957542009	B957542009 (A)	B957055 - 809
- 2	Denim 1 pedal	B957054908	B965464091 (DPX17 19#)	B956584501	B957402909	B9565883009	B956754009 (C)	B957490909
	Denim 2 pedals							B958318009
	Ordinary clothes	B957054905	B903695094 (DPX5 16#)	B957077501	B957542009	B958320009	B957542009 (A)	B957803809
	Knitted materials	B957054903	B903695001 (DPX5 9#)	↑	↑	↑	↑	B958319809

Different parts list

	Ret. No.	H - 15	H - 16	H - 22	J - 10	J - 10 - 1	K - 28	K - 31
Subclass	Parts Spec	Change gear (W)	Change gear (C)	Feed cam	Power cam set	Power cam assembly	Large shuttle hook	Inner rotary hook w/box
- 11	Ordinary clothes	B958389000 (42)	B958388000 (42)	B95838009 (425)	B955587809	B95177009	B958428909 (A)	BXF9229009 (A) (B958425)
- 2	Denim 1 pedal	↑	↑	B957057009 (42D)	BX97945809 (B)	BX97944009 (B)	BX958424909 (B)	BXF9228009 (B) (B958423)
	Denim 2 pedals							
	Ordinary clothes	B958391000 (28)	B958380000 (28)	B957787009 (28K)	↑	↑	B958428909	BXF9229009 (A) (B958425)
	Knitted materials	↑	↑	B958384009 (28M)	B955587809	B959177009	↑	↑

Different parts list

	Ret. No.	M - 11	M - 14	P - 17	Z - 13	Z - 13	Z - 15 - 2	Z - 15 - 2
Subclass	Parts Spec	Spring	Tension spring	Needle hole plate	Motor pulley 50HZ	Motor pulley 60HZ	V belt 50HZ	V belt 60HZ
- 11	Ordinary clothes	B965591009	B906585009	B954950009 (B)				B028905910 (M51)
- 2	Denim 1 pedal	B966522009 (B)	B903404009	B954959009 (C)	B956560009 (Ø14) B956568009 (Ø15. 88)	B956569009 (Ø14) B956567009 (Ø15. 88)	B028905810 (M52)	B028905910 (M51)
	Denim 2 pedals							B028905910 (M51)
	Ordinary clothes	B965591009	B906585009	B954950009 (B)				↑
	Knitted materials	B965591009	B906585009	B954961009 (A)				↑

Different parts list

	Ret. No.	Z - 16						
Subclass	Parts	Silicon oil						
	Spec							
- 11	Ordinary clothes	BX04304009						
- 2	Denim 1 pedal							
	Denim 2 pedals							
	Ordinary clothes	BX04304009						
	Kintted materials							

OPTION PARTS

WORK CLAMP LPL
B957808009

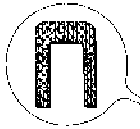

WORK CLAMP RPL
B957809009

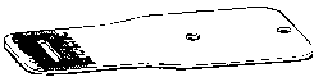
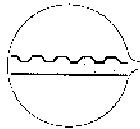

FEED PLATE PL

B957805809

WORK CLAMP LPS
B957806009

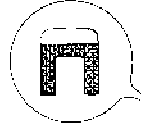

WORK CLAMP RPS
B957807009

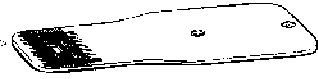
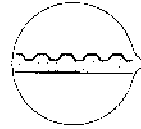

FEED PLATE PS

B957804809

WORK CLAMP L DENIM

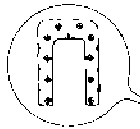

B958328009

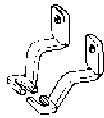

WORK CLAMP R DENIM

B958329009

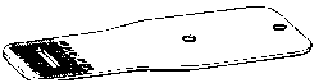
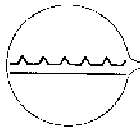

FEED PLATE DENIM

B958318009

WORK CLAMP L1 INCH

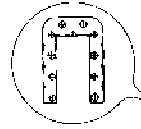

BX00103009



WORK CLAMP R1 INCH

BX00104009

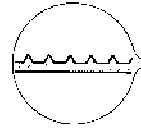

FEED PLATE 1 INCH

BX00102009



NEEDLE HOLE PLATE G
($\phi 2.5$)

B954955009



NEEDLE HOLE PLATE D
($\phi 2.5$
($\phi 2.5$ cross-shaped groove))

B954958009

$\phi 2.5$

Wa. Warning labels

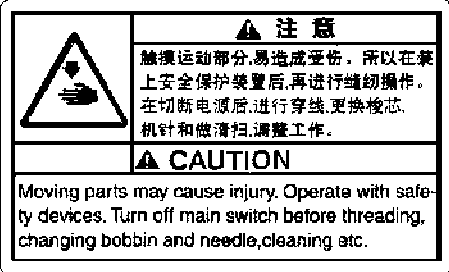
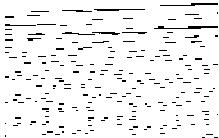
warning labels	Name of parts	size (mm)	Code
	operating attention label	52 × 84	BXF0317 - 009
	grounding mark	Ø12	BX73040 - 009

索引

零部件序号	参照号	页码	零部件序号	参照号	页码	零部件序号	参照号	页码	零部件序号	参照号	页码
B097390398	37	20	B092029888	32-3	2	B062060767	55-2	8	B048420212	54	28
	40	20	B092028088	4-1	14	B062050768	35-6	14		7	32
B097391698	32-8	2		26-2-1	14	B062050768	1-17	32	B048429698	64	4
B097340498	52	2	B092028588	11	6		5	34	B048390498	72	4
	5	18	B092500288	35-15	16		37	34		2	30
	32	30	B092509688	25	24		R-8	36	B048390398	6	2
B096420688	28	30	B092429088	3	34	B062040768	12	18	B048399698	5	2
	34	30	B089040908	24	42		19	18		8	2
	1-18	32	B089900808	32-15	2		Q-4	36	B048349698	3	2
B096480488	3	24	B089600904	S-1-13-2	38	B062020768	23	24		2	32
	Q-3	36		12-2	40	B062900968	32-13	2		20	34
	Q-9	36	B08950904	17-9-3	40	B062990968	31	6	B048329698	35	10
B096390588	Q-13	36		17-13-1	40		73	8	B039063450	36	16
B096340488	32	6	B089440908	135-1-4	42		27	18	B039015850	D-25	12
	34	6	B089430808	12-7	26		40	34	B038400740	3-2	22
	74	8	B089420808	39-7	6	B062980968	24	34	B038400340	D-9-2	12
	3	14	B089200908	22	6	B062950968	3	10	B038470840	5	10
	6-2-3	14	B085040978	78	8	B062940968	26	22	B029007430	13	24
	18	14		21	34	B062930968	2	22		19	24
	23	14	B085040878	80	8	B062920968	4	6	B029002030	52	34
	30-3	14		10	10		15	14		T-1-15	38
	32	14		39	16	B062860868	D-9-6	12	B028906219	15-1	40
	35-7	14		S-1-4	38	B062780868	32-2-1	2	B028905910	Z-15-2	45
	4	18	B085020978	65	4	B062750968	D-9-4	12	B028905810	Z-15-2	45
	10	18		11	18	B040430498	6	30	B028905510	Z-15-2	45
	16	18		18	18	B049440204	135-1-3	42	B900078006	43	34
	28	18	B085020878	32-4	2	B048040204	17-3-1	40	B900010006	23	6
	10	20		S-1-7	38	B048609694	S-1-13-3	38		2	24
	44-2	20	B085900978	32-16	2		12-3	40	B900974009	27	30
	19-3	22	B085750978	Q-17	36	B048509604	17-13-2	40	B900850009	16	10
	21	22	B085750778	12-4	26		17-13-3	40	B900795008	10	2
	30	22		R-4	36		17-13-4	40	B900740007	16	34
	6	24	B085420978	39-6	6	B048440698	16-4	24		T-1-9	38
	8	24	B085330878	11	2	B048440398	D-24	12	B900608006	10	30
	11	24	B085330878	Q-7	36		16-8	24	B900223009	4-1	40
	17	24		R-9	36	B048030698	49	20	B909538909	3-3	40
	26	34	B085200778	20	6		45	30	B909304009	18	10
	30	34		22	42	B048430598	21	26	B908470009	8	18
	42	34	B084070878	135-1-5	42		26	26	B908394006	1-5	32
	R-10	36	B084050974	17-13-6	40		33	26		1-22	32
	14	40	B082050868	45	6		39	26	B908267006	8	10
B096340478	14	10		60	8		48	26	B906650909	31	2
	21	10	B082050864	17-9-2	40		50	28		66	4
B096330488	17	10	B082040868	79	8		Q-15	36	B906585009	3-3	32
	19	10		82	8	B048430498	135-1-7	42		M-14	45
	D-8	12		26	42		13	26	B906543009	10	26
	14-2	24		32-5	2		4	30	B905659008	10	14
B096289088	6	6		12	6		40	30		25	14
	29	22		S-1-8	38		135-2	42	B905298007	S-1-9	38
B093048507	23	42	B082900868	32-17	2	B048430398	1-9	32	B904070009	19	40
B093399698	59	8	B078658804	17-3-2	40		1-19	32	B904963008	37	6
B093348098	S-1-3	38	B063869460	37	26	B048430298	15	2	B903072007	35-12	14
B093348808	66	8	B062070768	39-4	6		12-3	26	B903961009	27	22
B092040288	10-3	22		Q-11	36		35-22	16		59	28
B092049488	77	8		27	6	B048439098	R-3	36	B903879008	9	22
	42	20		33-4	6		12-8	26	B903695001	C-27	43
B092048888	8	20		D-1-5	12	B048439698	12-8	26	B903695094	C-27	43
	18	20		43-4	20	B048420498	59	2	B903404009	M-14	45
B092048578	55-3	8		30	30		5	26	B903366009	39-2	6
B092047088	12-1	14		18-3	34	B048420398	1-11	32	B903320009	4-2	40
	20-1	20		28	34	B048420298	22	2	B902845001	3-4	32
	29-1	20		Q-8	36		20-7	10	B902580009	30	2
	32-1	20		R-6	36		3	26	B901871008	18	2

索引

零部件序号	参照号	页码	零部件序号	参照号	页码	零部件序号	参照号	页码	零部件序号	参照号	页码
B990083009	44-1	20	B968899009	33	10	B959216909	24	6	B988433009	16-1	24
B990869009	38	6	B968867009	3-1	40	B959215000	25	6	B958432809	12	24
	67	8	B968482009	71	8	B959212009	26	6		18	24
B990815009	14-1	24		26	18	B959211009	28	6	B958431009	16-2	24
B990505009	72	8		39	34	B959100009	29	6	B958420009	16-3	24
B999960008	13	34	B968389009	5-2	40	B959108009	35	6	B958429809	24	24
	T-1-8	38	B968110009	17-11-3	40	B959107009	36	6	B958428909	K-26	44
B999245001	75	8	B968884009	25	42	B959106909	39	6	B958427909	16-5	24
	41	34	B968852009	24	10	B959105909	39-1	6	B958426909	16-6	24
B998842009	36	34	B968622009	M-11	45	B959104909	39-3	6	B958425107	K-31	44
B998441009	31	26	B968418009	6	26	B959103009	40	6	B958424909	K-26	44
	42	26	B968398009	2-1	10		54	8	B958423108	K-31	44
	56	28	B965792009	34	14		32	34	B958417009	D-1-1	12
B997004009	34	26	B965664009	12	30	B959102009	41	6	B958416009	D-1-2	12
B997794009	5	30		22	30	B959190009	43	6	B958415809	D-9-1	12
B997679008	39-5	6		3-2	32	B959198009	47	8	B958412909	D-9-3	12
	61	8	B965632909	35-7	16	B959197009	49	8	B958411009	D-9-5	12
B996816009	17	30	B965620909	12	2	B959196009	50	8	B958300000	D-9-7	12
B996827008	10	40	B965591009	M-11	45	B959195909	52	8	B958309009	D-18	12
B996824008	71	4	B965464091	C-27	43	B959191909	57	8	B958308009	D-19	12
B996125009	58	2	B964766009	35-14	16	B959180009	58	8	B958307900	D-20	12
B995098008	13	6		29	30	B959188009	65	8	B958305909	D-22	12
B995092009	19	6		27	34	B959187009	68	8	B958304909	D-23	12
B995033007	38	30	B964715000	23	26	B959186009	69	8	B958302000	4	20
B995972009	1-13	32	B961999009	D-7	12	B959185009	70	8	B958301000	6	20
B995953009	5-5	40	B963959000	3	20	B959183009	2	6	B958390009	7	20
B995817008	17	2	B963365000	2-6	26	B959182009	1	22	B958397009	5	20
B994094009	S-1-13-4	38		15	26	B959170709	3-1	22	B958392009	2	20
	12-4	40		43	26	B959178009	8	22	B958391000	H-15	44
B994925801	S-1-13	38	B964735000	14	26	B959177009	J-10-1	44	B958380000	H-16	44
	12	40	B961863009	S-1-12	38	B959174009	11	22	B958389000	H-15	44
B994481009	35-5	14		18	40	B959173009	12	22	B958388000	H-16	44
B994481009	Q-5	36	B950938007	17-12	40	B959172009	13	22	B958387009	34	20
B994180009	36	10	B950937007	17-8	40	B959171909	55	8	B958386009	19	20
B994188009	9	30	B950936000	17-7-1	40	B959160009	10-2	22	B958384009	H-22	44
B993950009	25	26	B950931008	17-9-1	40	B959169709	10-4	22	B958383009	H-22	44
	38	26	B950928000	17-5	40	B959166009	19	22	B958382009	23	20
B993747009	44	6	B950927000	17-11-2	40	B959164000	D-17	12	B958379909	35	20
B993673901	S-1-13-1	38	B950921901	17-1	40	B959163909	19-1	22	B958378009	36	20
	12-1	40	B950804008	40	22	B959162009	19-2	22	B958377009	39	20
B993176009	29	2	B950775009	5-4	40	B959161009	20	22	B958376009	41	20
B993174009	27	2	B950557009	53	8	B959159009	22	22	B958375909	43	20
B992048009	5-3	40		64	8	B959157009	25	22	B958371009	43-2	20
B992273009	3-2	40		33	34	B959156009	28	22	B958369809	1	14
B980672009	34	24		S-1-5	38	B959113000	4	10	B958368909	1-1	14
B980662009	1-21-2	32	B950556008	14	6	B959112000	6	10	B958366009	2-2	18
	30	42	B950554009	46-3	6	B959111009	7	10	B958365009	2	14
B988119009	1	40		48	8	B958000001	13	10		31	14
B978059009	20-4	10		51	8	B958919909	9	24	B958361009	7	14
B960718001	28	2		20-3	18	B958879000	15	10		27	14
B960687000	2-5	26		22	18	B958878909	20	10	B958350009	8	14
	28	26	B959947009	9	6	B958874009	20-1	10		28	14
B960384000	11	10		24	20	B958873909	20-3	10	B958358009	6-2-1	14
B969779009	36-3	16	B959408008	1-3	14	B958872009	20-5	10	B958355009	11	14
B969776009	47	20	B959406008	54	2	B958871009	20-6	10	B958354009	14	14
	48	34	B959224009	1	6	B958860909	22	10		19	14
B969638008	23	22	B959223009	3	6	B958868009	25	10		21	14
B969550009	1-147	32	B959222909	10	6	B958867009	26	10	B958352009	16	14
B969527909	21	18	B959221009	15	6	B958866000	34	10	B958351009	17	14
B969418009	12-6	26	B959210000	16	6	B958865909	4	24	B958340569	20	14
B969324009	1	24	B959219009	17	6	B958864909	5	24	B958345009	6	40
B969240009	32-2-2	2	B959218009	84	8	B958863009	7	24	B958344009	33	14
B968008009	5-1	40	B959217009	21	6	B958860009	10	24	B958343501	F-35	43

索引

零部件序号	参照号	页码	零部件序号	参照号	页码	零部件序号	参照号	页码	零部件序号	参照号	页码
B958341909	36	16	B958242001	55	2	B958159009	2-2	26	B957906009	17	20
B958339000	36-1	16	B958241009	1	30	B958157009	45	26	B957972009	46	30
B958338009	37	16	B958230009	3	30	B958155009	4-2	26	B957969009	48	20
B958337000	36-2	16	B958238009	8	30	B958154009	4-3	26	B957915009	43-3	20
B958336009	35-2	14	B958237009	16	30		7	26	B957809009		47
B958335009	35-3	14	B958236009	19	30	B958152009	4	26	B957808009		47
B958333009	F-35-8	43	B958235009	20	30	B958151009	4-1	26	B957807009		47
B958332009	F-35-9	43	B958234009	21	30	B958140009	9	26	B957806009		47
B958331009	F-35-8	43	B958233009	23	30	B958149009	12	26	B957805809		47
B958320009	F-35-9	43	B958232009	24	30	B958148009	8	26	B957804809		47
B958329009	F-35-8	43	B958231909	25	30	B958147009	12-5	26	B957803809	F-44	43
		47	B958220009	26	30	B958146009	17	26	B957891009	46	34
B958328009	F-35-9	43	B958229009	31	30		19	26		T-1-12	38
B958328009		47	B958227000	43	30	B958145009	18	26	B957880009	45	34
B958327009	35-10	14	B958226009	44	30	B958144009	12-1	26		T-1-11	38
B958326009	35-11	14	B958224009	33	30	B958143009	12-2	26	B957888009	8	34
B958322000	35-19	16	B958223009	35	30	B958142009	60	28		T-1-3	38
B958319809	F-44	43	B958221009	39	30	B958141009	20	26	B957770909	20-1	10
B958318009	F-44	43	B958210009	41	30		32	26	B95777909	30-1	14
		47	B958219909	42	30	B958139009	29	26	B957778009	43-1	20
B958316009	1	18	B958218009	1	34	B958137009	36	26	B957767009	H-11	44
B958313809	2	18	B958217909	4	34		67	28	B957628009	38	34
B958312809	2-1	18	B958214009	2	34	B958136009	41	26	B957626009	33-3	6
B958311009	3	18	B958213809	9	34	B958134009	49	28	B957582009	64	28
B958209809	6	18	B958213809	T-1-4	38	B958133009	52	28	B957581909	61	28
B958208009	7	18	B958109009	10	34	B958132009	53	28	B957570009	62	28
B958208009	9	18		T-1-5	38	B958120009	52-1	8	B957579009	63-1	28
B958207009	13	18	B958106009	11	34	B958120009	70	28	B957548009	63-2	28
B958206909	14-1	18		T-1-6	38	B958129009	7	34	B957543000	35-20	16
B958204909	14-2	18	B958105009	12	34		T-1-2	38	B957548009	F-35-18	43
B908202909	46	16		T-1-7	38	B958128801	1	32		F-35-18	43
	20	18	B958104909	50	34	B958127901	1-1	32	B957530009	35-16	16
B958299009	23	18		T-1-13	38	B958126058	1-2	32	B957539009	35-13	16
B958295009	Q-1	36	B958198009	18-1	34	B958125009	46	26	B957536809	28	42
B958294009	Q-2	36	B958197009	18-2	34	B958122009	R-5	36	B957514009	54	34
B958288909	Q-6	36	B958196009	55-1	8	B958121009	20	2	B957514009	T-1-17	38
B958287009	Q-10	36		38	20	B958118009	24	26	B957513009	53	34
B958283009	Q-12	36		18-4	34	B958115009	6	34		T-1-16	38
B958270901	2	2	B958195009	19	34		T-1-1	38	B957512009	51	34
B958279009	4	2	B958194009	22	34	B957077501	F-35	43		T-1-14	38
B958278901	4-1	2	B958193009	23	34	B957076301	F-35	43	B957402909	F-35-8	43
B958277009	4-2	2	B958191009	18-6	34	B957075000	43	16	B957190909	F-44	43
B958276001	7	2	B958180009	29	34	B957060009	2	10	B957353009	26-2	14
B958275001	9	2	B958189009	31	34	B957069009	1-2	14	B957348809	4	14
B958273901	13	2	B958188009	34	34	B957068009	6-1	14	B957347009	47	26
B958272009	60	4	B958187009	35	34		26-1	14	B957192009	2-4	26
B958271009	61	4	B958185909	R-1	36	B957067009	6-2-2	14	B957191009	2-7	26
B958269801	14	2	B958184009	R-2	36		30-2	14	B957189009	1-5	14
B958268051	16	2	B958181009	R-7	36	B957066909	D-1	12	B957188009	44	26
B958263001	77	4	B958177009	1-3	32	B957065009	9	14		58	28
B958262009	63	4	B958176009	1-4	32		24	14	B957186009	1-4	14
B958258909	32-2	2	B958175009	1-6	32	B957063009	6	14	B957185009	68	28
B958253009	32-6	2	B958174009	1-7	32	B957062009	26	14	B957184009	69	28
B958252009	32-7	2	B958173009	1-8	32	B957061009	7	30	B957183009	55	28
B958251009	32-9	2	B958172009	1-10	32	B957050000	16-9	24	B956955909	63	8
B958240001	32-10	2	B958171009	1-12	32	B957057009	H-22	44	B956778009	46-1	6
B958249909	32-11	2	B958160009	1-15	32	B957055809	F-44	43		20-1	18
B958248006	32-12	2	B958169009	1-20	32	B957054909	A-62	43	B956777009	46-2	6
B958247009	20	40	B958165009	3-1	32	B957054908	A-62	43		20-2	18
B958246000	21	40	B958162009	1	26	B957054905	A-62	43	B956771909	35-1	24
B958245809	32-14	2		11	26	B957054903	A-62	43	B956769009	35-2	24
B958244009	51	2	B958161009	2	26	B957053908	42	16	B956754009	F-35-8	43
B958243000	53	2	B958150009	2-1	26	B957052009	D-1-4	12		F-35-8	43

Index

No.	Ret. No.	Page	No.	Ret. No.	Page
B956662009	S-1-2	38	BX07415009	83	8
B956661009	S-1-6	38	BX07306008	14	24
B956650009	S-1-10	38	BX04304009	Z-16	46
B956659909	S-1-11	38	BX03730908	37	30
B956658009	S-1-1	38	BX03297009	51	20
B956645009	70	4	BX03296009	52	20
B956584501	F-35	43	BX01978059	12	14
B956583009	F-35-9	43		20	20
B956582009	1-21-1	32		29	20
B956560009	Z-13	45		32	20
B956569009	Z-13	45	BX01442009	1-16	32
B956568009	Z-13	45	BX90641009	18	30
B956567009	Z-13	45	BX99866009	44	34
B956429009	S-1-14	38	BX98669009	48	30
B956301008	S-1	38	BX97945809	J-10	44
B956372901	32-1	2	BX97944009	J-10-1	44
B956340009	31	43	BX92684009	T-1	38
B956325000	74	4	BX89980009	D-26	12
B956322009	25	34	BX89355009	44	20
B956381009	18-5	34	BX89312009	17-9	40
B955774009	46	20	BX79078009	15	30
B955773009	43-5	20	BX79775009	33	6
B955621000	18-10	24	BX79774009	33-1	6
B955611009	62	8	BX76209009	5	6
B955500009	76	8	BX76207009	8	6
B955509009	42	6	BX76206009	30	6
B955587809	J-10	44	BX76204009	18	6
B954961009	P-17	45	BX76283009	24	22
B954950009	T-1-10	38	BX76271009	35-4	14
	P-17	45	BX75393009	36	30
B954959009	P-17	45	BX75272009	D-1-3	12
B954958009		47	BX74423000	19-1	2
B954955009		47	BX74421000	19-2	2
B954804009	Q-14	36	BX74410009	21	2
B954615809	35-21	16	BX73799009	1	20
B954174809	3	22	BX73789000	10-1-1	22
B952424009	15	18	BX73788000	7	6
B952423009	24	18	BX73779009	E	12
B951490709	35	24	BX72776009	25	20
B951498009	35-3	24	BX72774009	1	10
B951497059	36	24	BX72761009	Wa	48
	7	40	BX71990009	9	10
B951805009	13	30		40	16
B951202901	32	2	BX60471009	17-7	40
B951133900	9	20	BX60469009	17-3	40
B951132009	11	20	BX69897000	2-3	26
B951131009	12	20	BX66627009	135-1-1	42
B951126009	13	20	BX66685009	135-1-2	42
B927424909	D-9	12	BX66684909	135-1-6	42
B608223009	16-7	24	BX66617909	135-1	42
BX00783709	16	24	BX81518909	35-1	14
BX00600000	16-11	24	BX50003009	135	42
BX00387009	33-2	6	BX59828009	17-6	40
BX00104009		47	BX59827009	17-4	40
BX00103009		47	BX55447009	11	40
BX00102009		47			
BX09700000	3	32			
BX08349709	17	40			
BX08337009	17-3	40			
BX08332008	17-10	40			
BX08324008	17-11	40			
BX08323008	17-11-1	40			
BX08232000	D-21	12			

Kinds of machines

GT680—

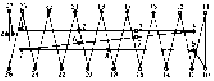
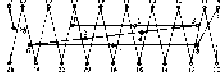
Sub - class	-011	-021 -022	-0311 -032	-041
Main uses	Ordinary clothes	Denim	Ordinary	Knitted clothes
Decorative stitching				
Number of stitching	42		28	
Tack length	7 ~ 16	7 ~ 20	4 ~ 10	4 ~ 8
Tack width	1 ~ 2	1 ~ 3	1 ~ 2	
Needle	DP x5#16	DP x17#19	DP x5#16	DP x5#9
presser foot stroke	17mm			
Sewing speed	2,000rpm			

The maximum possible bar tack length and width for this machine are given above.

table

Use one of following special type power tables.

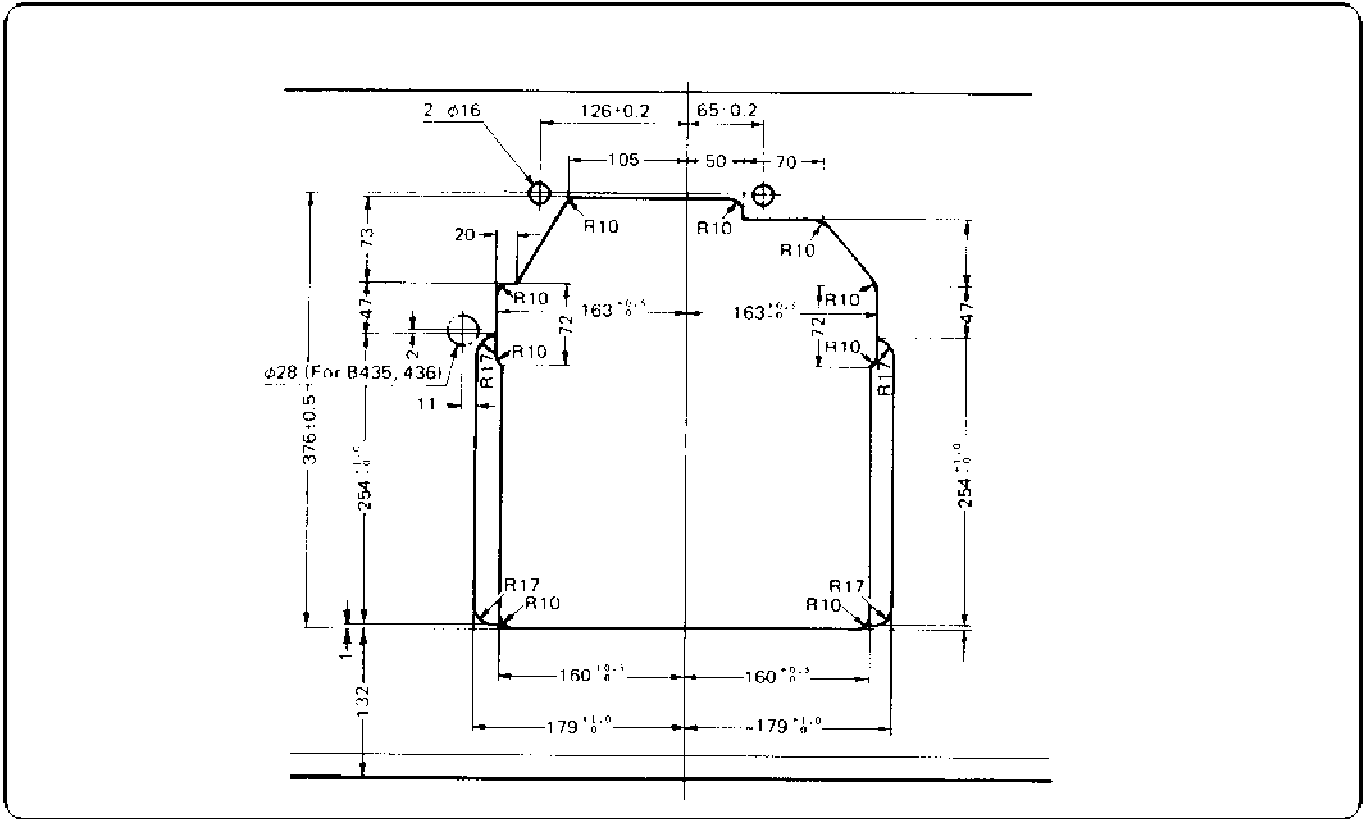

Installing the motor

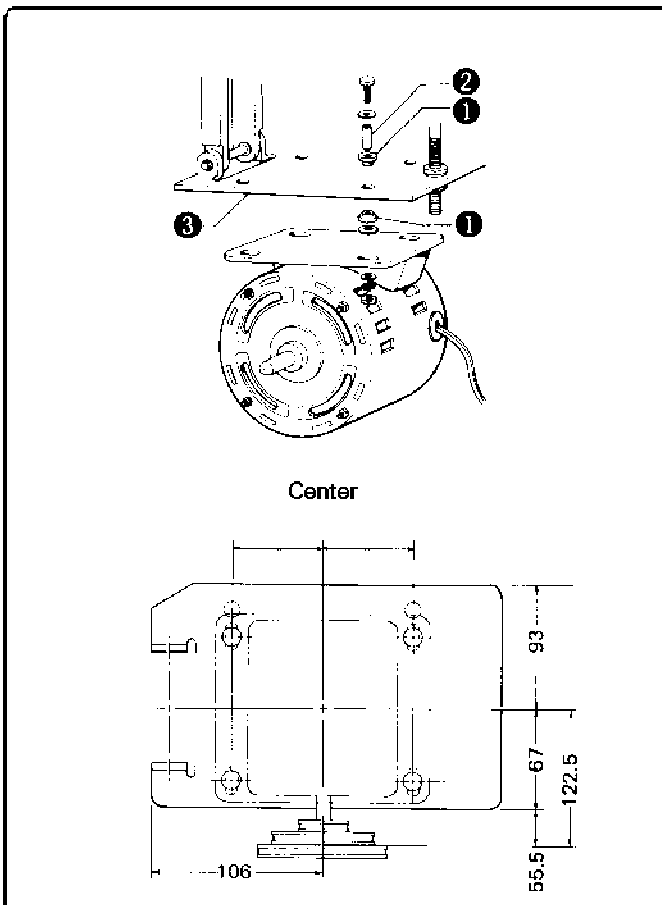

Fit the cushions ① and cushion collars ② supplied into the four places in the motor base ③, and install the motor as shown in the above diagram.

★ If you have purchased a motor separately, it may not be installed on motor base. If this is the case, purchase a separate motor base without holes and then make the holes to the measurements shown in the above diagram.

Installing the machine head

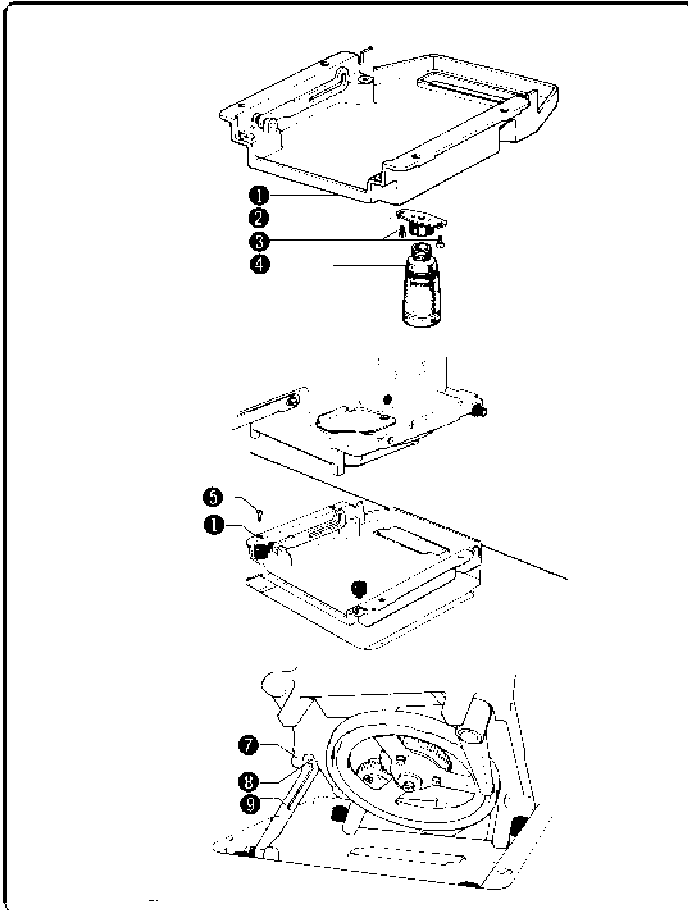

1. Place the poly - oiler support ② under the oil pan ①, and tighten the two screws ③; then attach the main body of the poly - oiler ④ .
2. Attach the oil pan ① to the table, using four flat - head wooden screws ⑤ .
3. Attach the bed cushions ⑥ to the four corners of the oil pan ①, then carefully place the sewing machine on top of the oil pan .
4. Tilt the machine back toward the opposite side, loosen screw ⑦ fit the head support pin ⑧ into the oblong hole in the head support lever ⑨, and then tighten screw ⑦ .
5. To return the machine to its original position, pull the head support lever ⑨ towards you and gently lower the machine into position.

Installing the motor pulley and belts

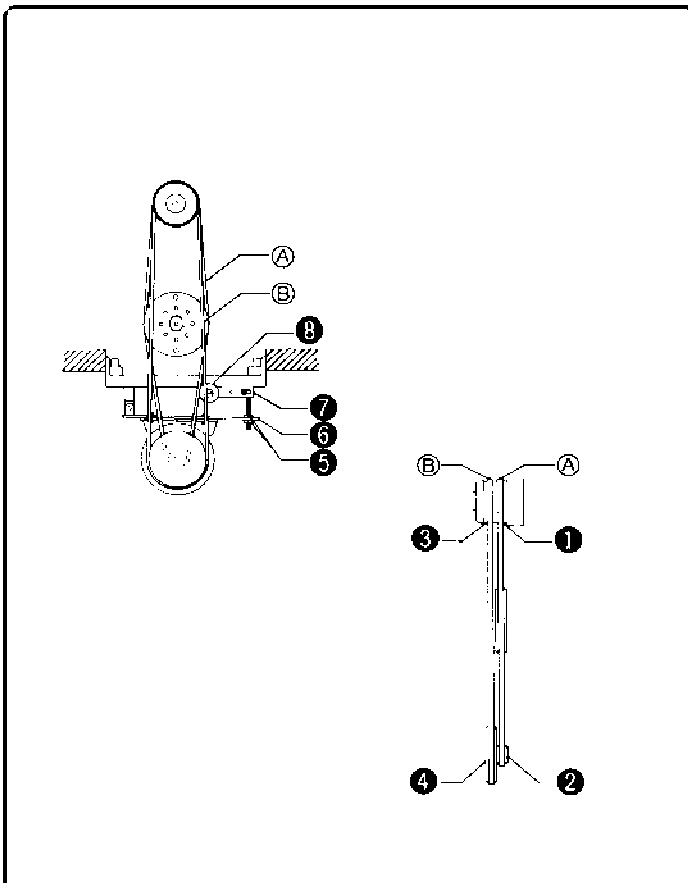

1. Push the motor pulley completely onto the motor shaft, and then insert one of the two motor pulley set screws through the opening on the motor pulley and screw it down until it contacts the flat surface of the shaft.
 2. Pass the low speed belt around the low speed pulley ① and the narrower part of the motor pulley ② .
 3. Pass the high speed belt around the high speed pulley ① and the wider part of the motor pulley ④ .
 4. To adjust the tension of the high speed belt B, loosen nut ⑤ and move the motor base ⑥ up or down so that the high speed belt B will bend about 10mm when depressed around the center with your finger.
 5. After adjusting the high speed belt B, adjust the tension of the low speed belt A as follows. Loosen bolt ⑦, and move the tension pulley ⑧ to the left or right so that the low speed belt will bend approximately 10mm.
- ★ If the belt tension is stronger or weaker than necessary, the machine may not operate properly. Always check the tension of the belts.

Motor pulley and belts

The maximum rpm of this sewing machine is 2,300. But if synthetic fiber is used for the cloth thread, the machine should be used at a speed of 2,000 rpm to prevent the thread from breaking through overheating. If you wish to use a 1800 or 2300 rpm motor pulley and belts, purchase one of the following models separately.

Frequency	Sewing speed	Motor pulley	High speed belt (in)	Low speed belt (in)
50HZ	2,300	B956560009	B0289050810 (52)	B028906219 (48)
	2,000			
	1,800	B957901009	B028905910 (51)	
60HZ	2,300	B956569009	B028905910 (51)	
	2,000			
	1,800	B957902009	B028905010 (50)	

Installing the spool holder base

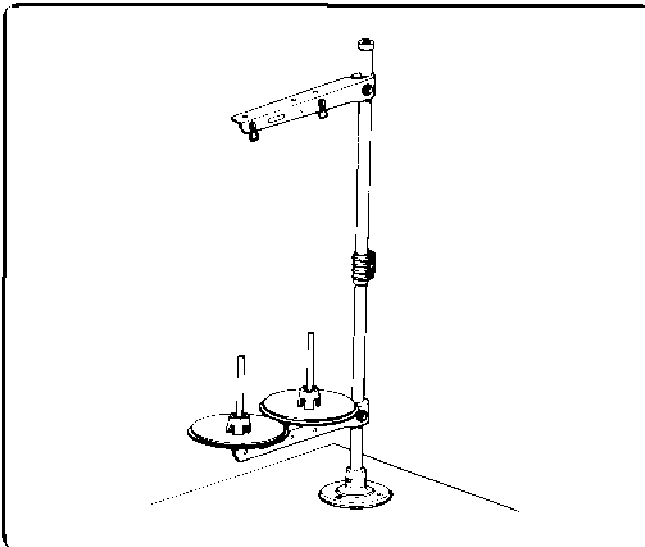

Install the spool holder base in the far right corner of the table.

Installing the bobbin winding thread guide

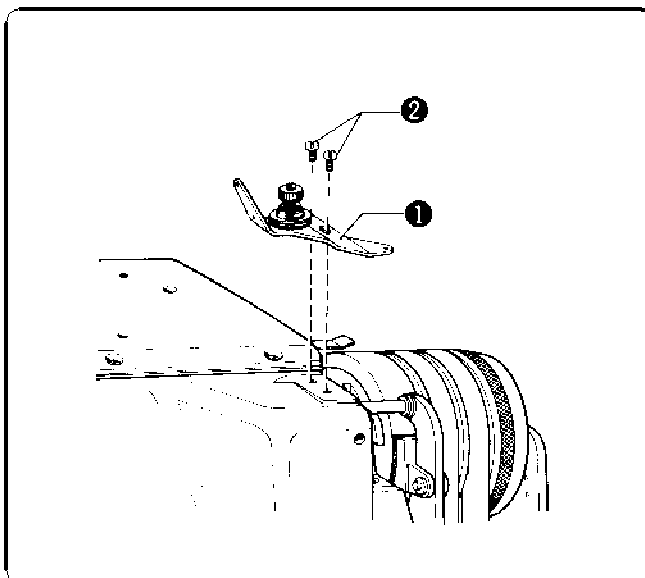

Set the bobbin winding thread guide ① on upper part of the arm with two clamping screws ②.

Installing the pedal

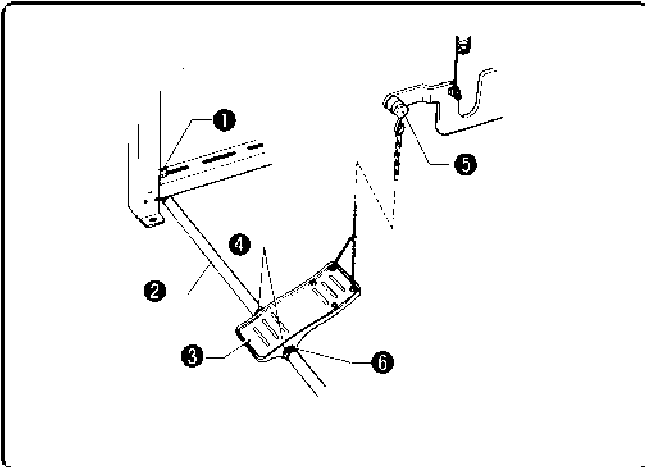

1. Loosen the hexagonal bolt ① and fit the pedal ③ and pedal fasteners ④ onto the support axle ② .
2. Hang the end of the chain over the presser lifter lever screw ⑤ . Then pass the lower end of the chain through the holes in the pedal ③ and adjust it to a suitable length.
3. To adjust the position of the pedal ③, move the support axle ② backward or forward and the pedal fasteners ④ to the right or left. Then tighten the hexagonal bolt ① and the screw ⑤ .

For sewing machines equipped with mechanical two –pedal systems

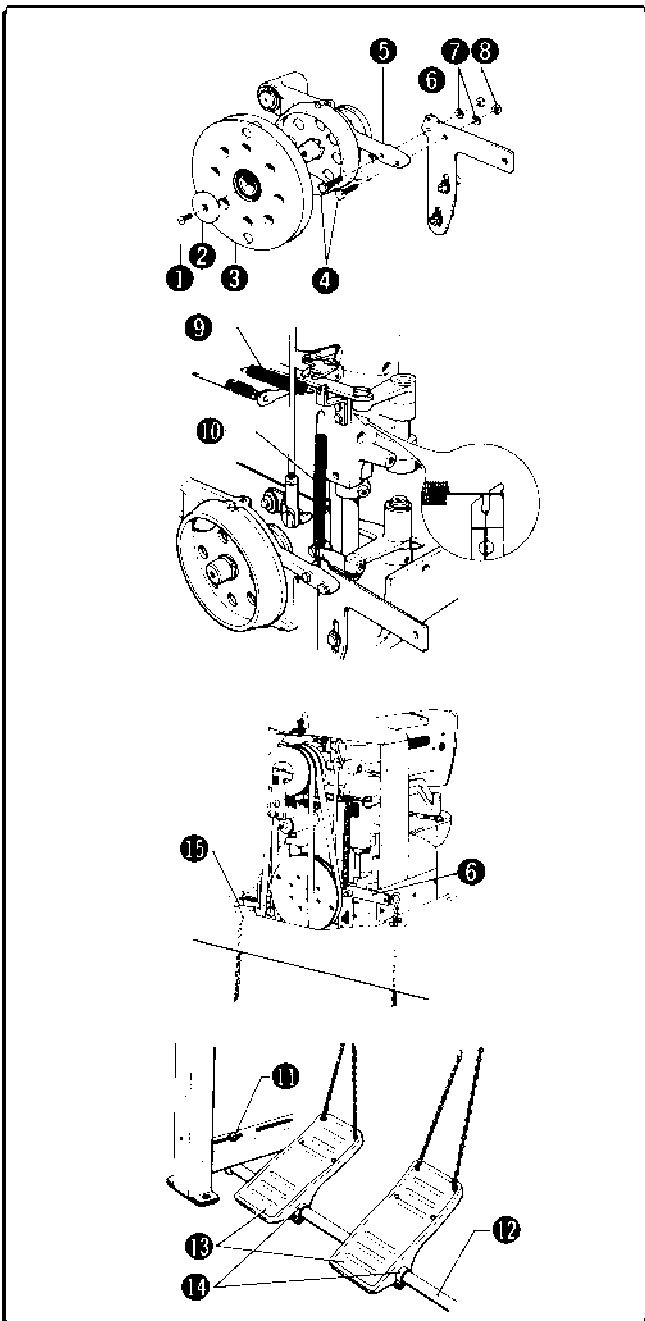

1. Loosen the flat – head screw ①, then remove the metal washer ②, and the power pulley ③ .
2. Attach the hexagonal bolts ④ to the drive lever ⑤; attach the drive lever plate ⑥, metal washers ⑦, and the nuts ⑧, to the tips of the hexagonal bolts.
3. Attach the clutch tension spring ⑨ to the second hole.
4. Attach the drive lever tension spring ⑩ to the drive lever plate, and the clutch tension spring mount .
5. Loosen the hexagonal bolt, and attach the pedals, and the pedal fasteners, to the support axle 12.
6. Hook the chain to the presser lifter lever screw 15, then pass the lower end through the hole in the right – hand pedal and adjust it to an appropriate length.
7. Hook the other chain to the drive lever plate ⑥, then pass the lower end through the hole in left – hand pedal, and adjust it to an appropriate length .

Installing the belt cover

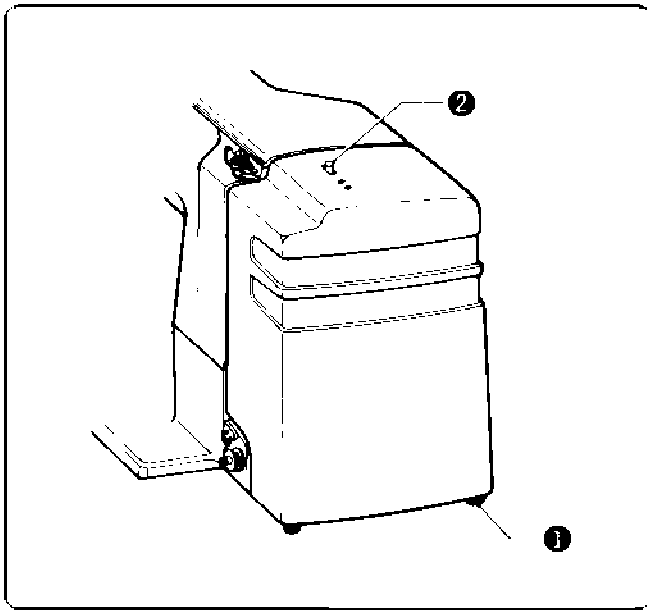

Fit the belt cover cushions ① into the holes in the table top, and then fit the belt cover gently over the belts while button ② is depressed.

Lubrication

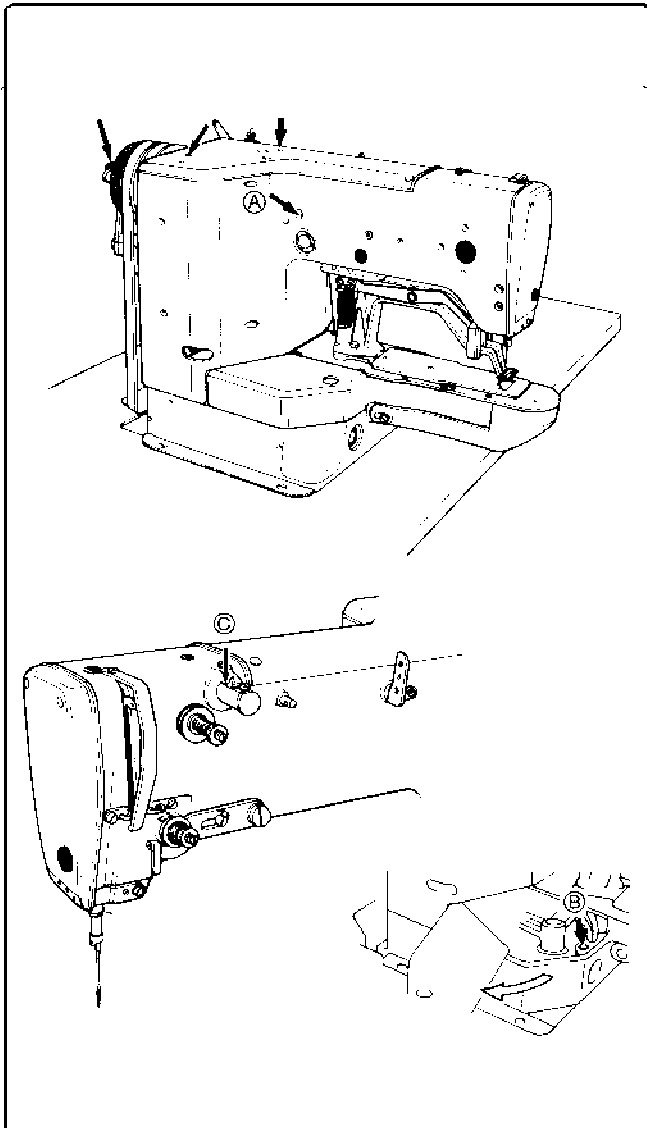

- Everyday, before using the machine, apply one or two drops of machine oil (White, oil 70) to the places indicated by the arrows, Fill the oil tanks A and B also.
- Fill the liquid - cooled tank C with silicon oil (100CS)

Trial operation

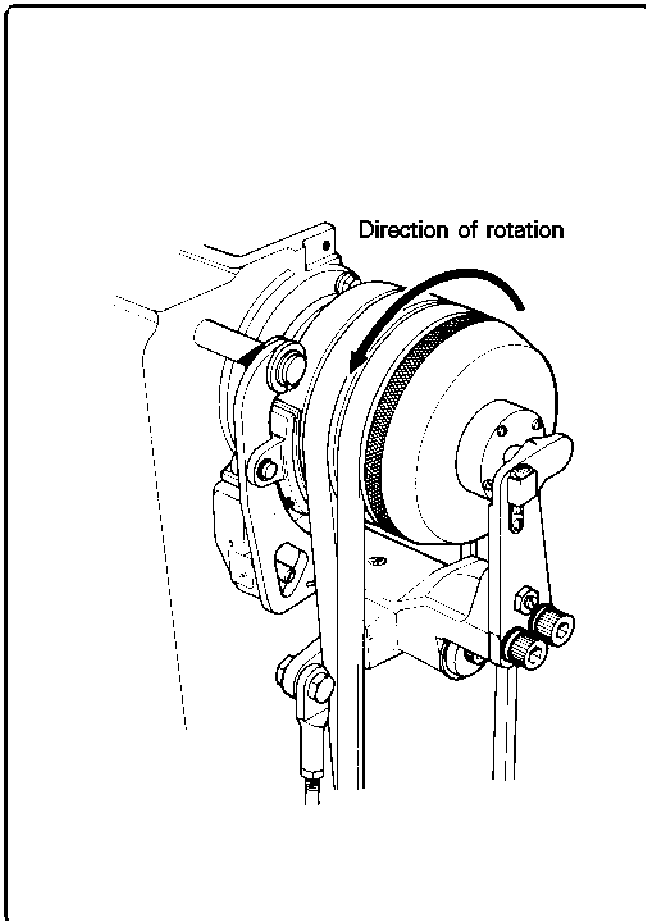

Follow the procedure below to start the machine operating .

1. When the power switch is turned on the motor will start to operate and the high speed and low speed pulleys will revolve in the direction shown by the arrow.
2. Depress the pedal one to step to lower, the work clamp, If you want to raise the work clamp again, release the pedal and the work clamp will come up.
3. Depress the pedal to the next step and the machine will start. When this happens, release the pedal immediately .

4. After sewing a fixed number of stitches the thread will be trimmed , the work clamp will rise , and the machine will stop automatically.

★For sewing machines equipped with mechanical two –pedal systems

1. When the left pedal is depressed, the work clamp is raised; when the pedal is released , the work clamp returns to its original position .
2. When the right pedal is depressed, the sewing machine starts . Operating the sewing machine in the wrong direction can damage it; always make sure the machine is running in the right direction.

Checking the basic operation of the machine

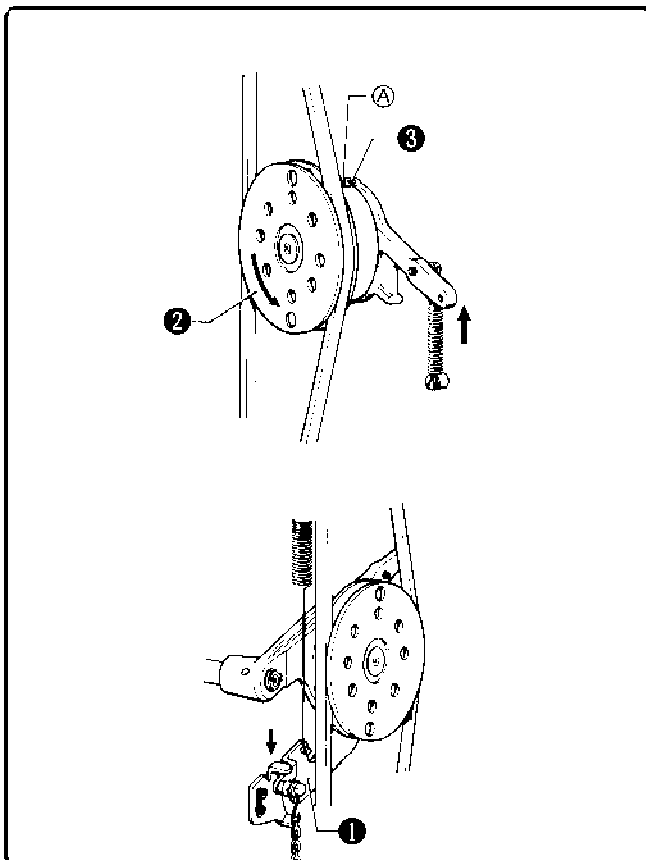

Proceed through the following steps to adjust the machine so that it can be turned by hand. Then check the basic operation of the machine .

1. With the machine in the stop position and the power actuating lever ① lowered, rotate the power pulley ② in the direction of the arrow .

The work clamp will come down, and the groove on the power cam will be aligned with the approximate center of the roller ③ .

2. Lower the power actuating lever ① completely to raise the clutch .
3. Turn the pulley for three revolutions, and then release the power actuating lever ① .

Basic operation of the power presser lifter

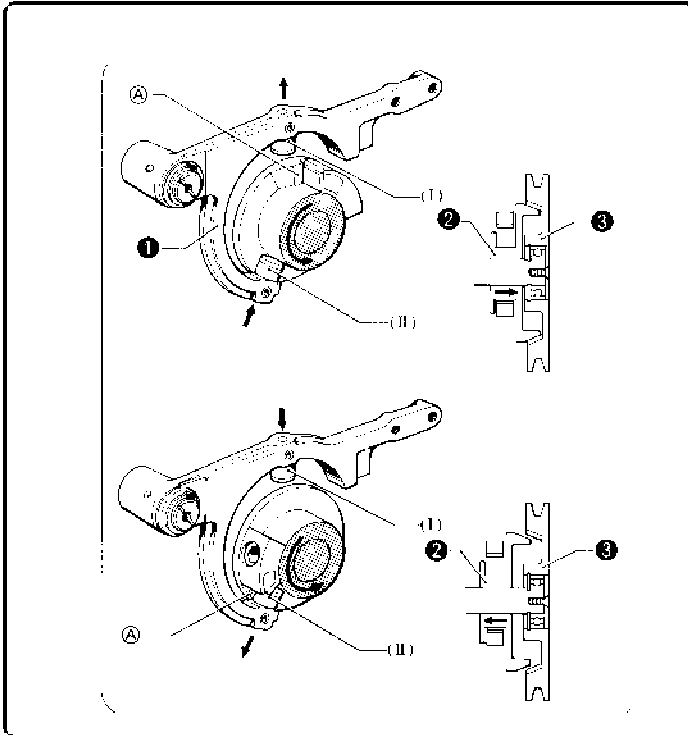

When the drive lever ① is raised, roller (I) will disengage and move upwards and power cam ② will move into contact with the power pulley ③ . When this happens power will be transmitted to power cam ② , and clutch cam ② part A will rotate up to the position of roller (II) . Then , when clutch cam part A pushes against roller (II) and disengages again , power cam ② will disengage from the power pulley ③ and the power will be cut off. While clutch cam part A rotates from roller (I) to roller (II) the work clamp comes down.

With the final stitch , roller (II) disengages and moves downwards and , as before, power cam ② moves into contact with power pulley ③ and clutch cam part A rotates from roller (II) to roller , (I) . During this movement the work clamp rises . Finally, the power is cut off when clutch cam part A contacts roller (I) and power cam ② disengages from power pulley ③ .

Basic operation of the upper tension discs

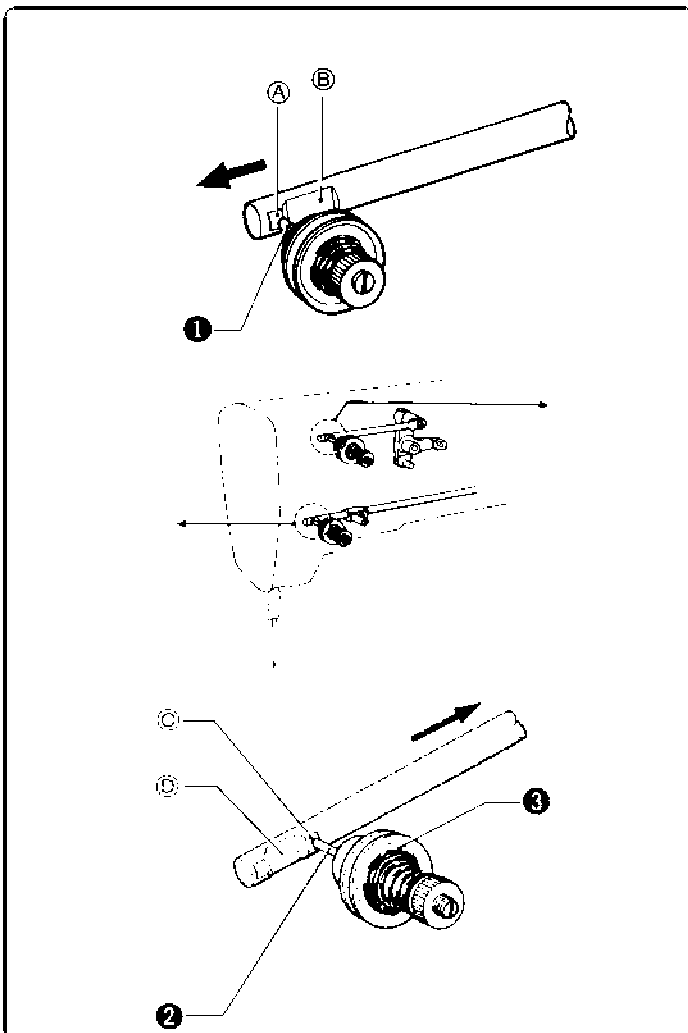

* When the machine is at a standstill, the tension releasing pin ① is at the position of cam part A and the main tension disc is released. When the machine starts , the tension releasing pin ① moves into cam part B, and the main tension disc closes . While sewing the disc always supplies adequate tension to the upper thread. With the final stitch the clutch engages, the tension releasing pin ① moves up to cam part A , and the main tension disc releases.

* The outer spring of the auxiliary tension disc always supplies weak tension to the upper thread, irrespective of whether the machine is sewing or not . The tension releasing pin ② of the auxiliary tension disc is at the position of cam part C , and the tension releasing disc ③ is floating . With the final stitch the clutch engages and, before the moving blade operates and trims the thread, the tension releasing pin ② moves into cam part D and the tension releasing disc ③ momentarily increases the tension on the upper thread to prevent it from being drawn out from the spool when trimmed. Thus, the remaining end of thread from the needle is always cut to a uniform length.

Basic operation of the clutch

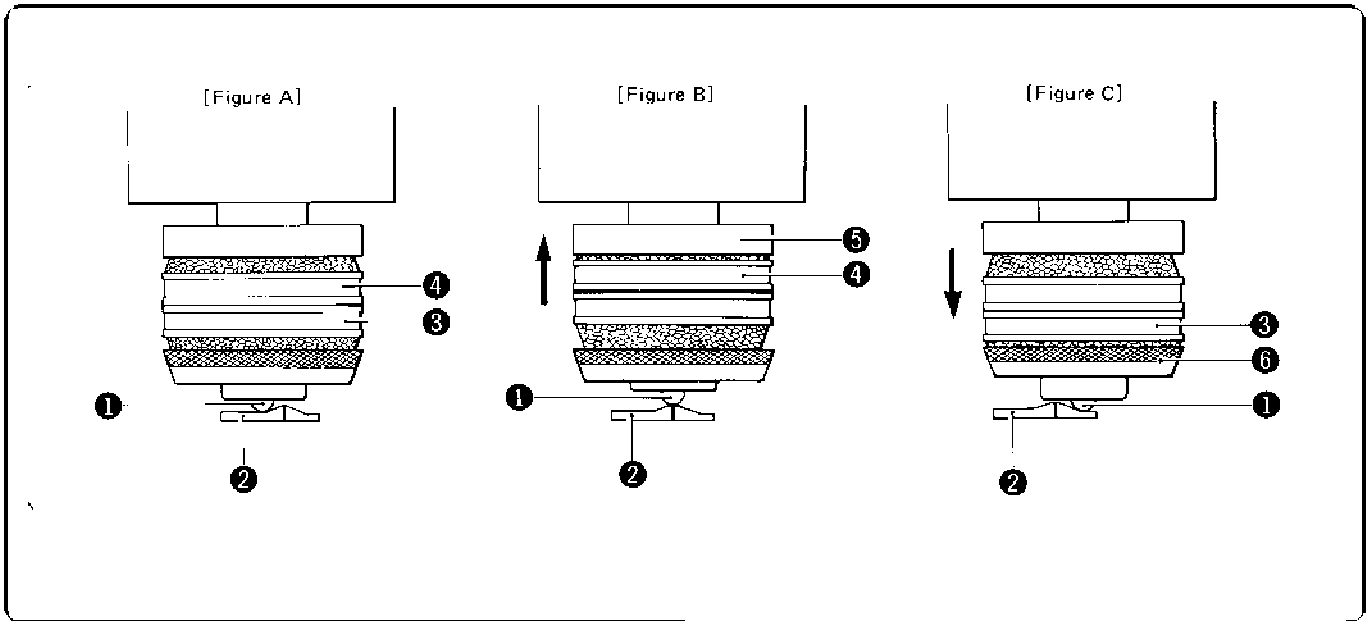

When the machine is at a standstill the steel ball ① and the ball presser plate ② are in the positions shown in Figure A, and the high speed pulley ③ and the low speed pulley ④ are idling. When the ball presser plate ② moves to the position shown in Figure B the low speed pulley ④ presses against stop cam ⑤ and two stitches are sewn at low speed. This is to prevent the thread from slipping out of the needle at the commencement of sewing. The ball presser plate ② then moves to the position shown in Figure C, the high speed pulley ③ presses against the clutch disc ⑥, and high speed sewing begins. When stitching is completed to the fourth stitch from the end, the ball presser plate ② moves to the position shown in Figure B and slow speed sewing begins again. This eases the shock of stopping and preserves the excellent durability of the sewing machine.

Basic operation of the moving blade

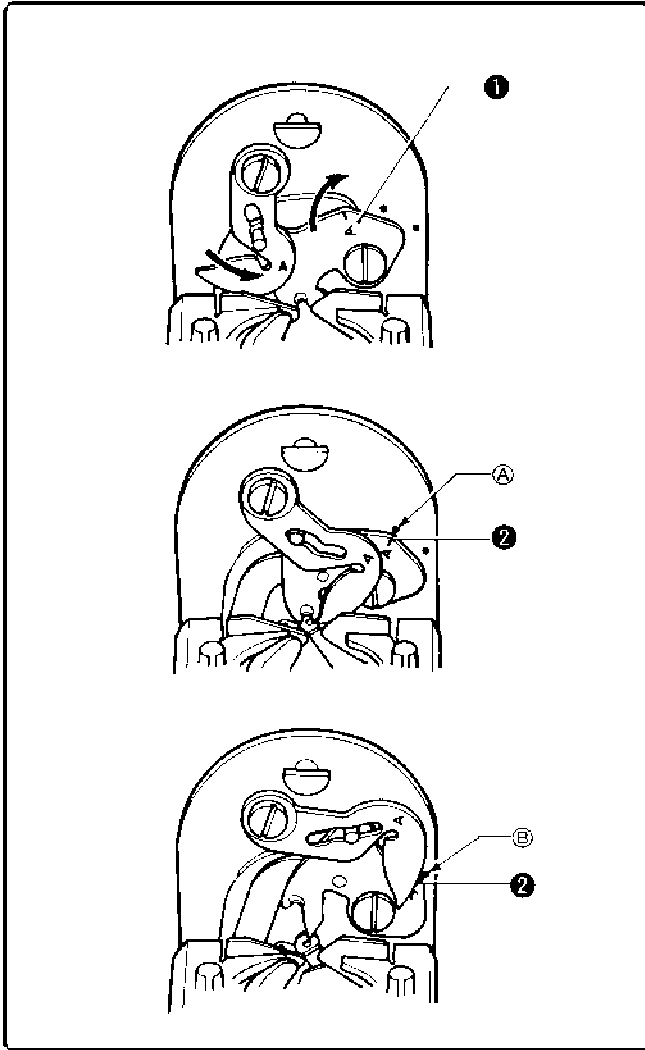

When the sewing machine is stopped, the moving blade is in its rest position. When the work clamp begins to lower, the moving blade moves in the direction indicated by the arrow, and is returned forcefully to the position where the moving blade take-in ②, matches the needle plate take-in A. The moving blade ① moves again, so that the moving blade take-in ② matches the needle plate take-in B. At the final stitch, the moving blade ① scoops up the upper thread loop, and returns again to the needle plate take-in position A.

Before the clutch is engaged and the work clamp is raised, the moving blade ① cuts the thread.

Installing the needle

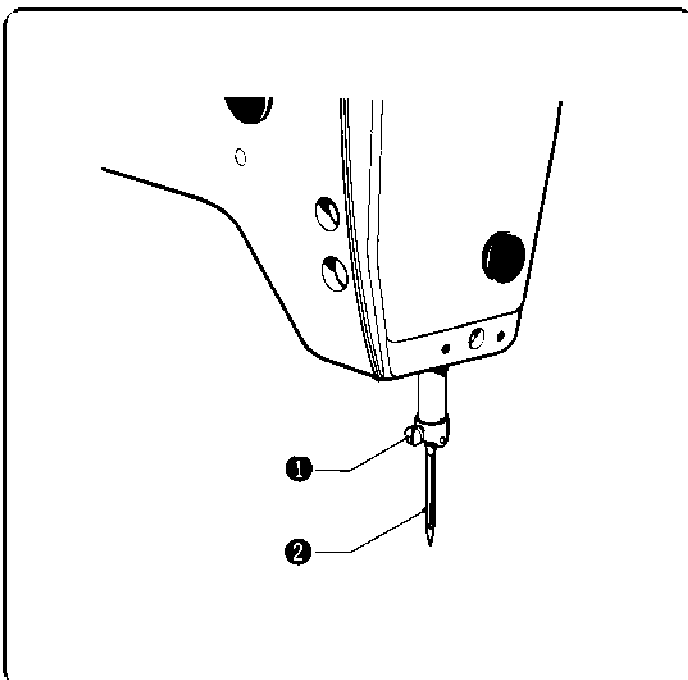

Loosen screw ①, hold the needle ② with the long groove facing the front, push it in completely until it hits the end, and then tighten set screw ①.

Upper threading

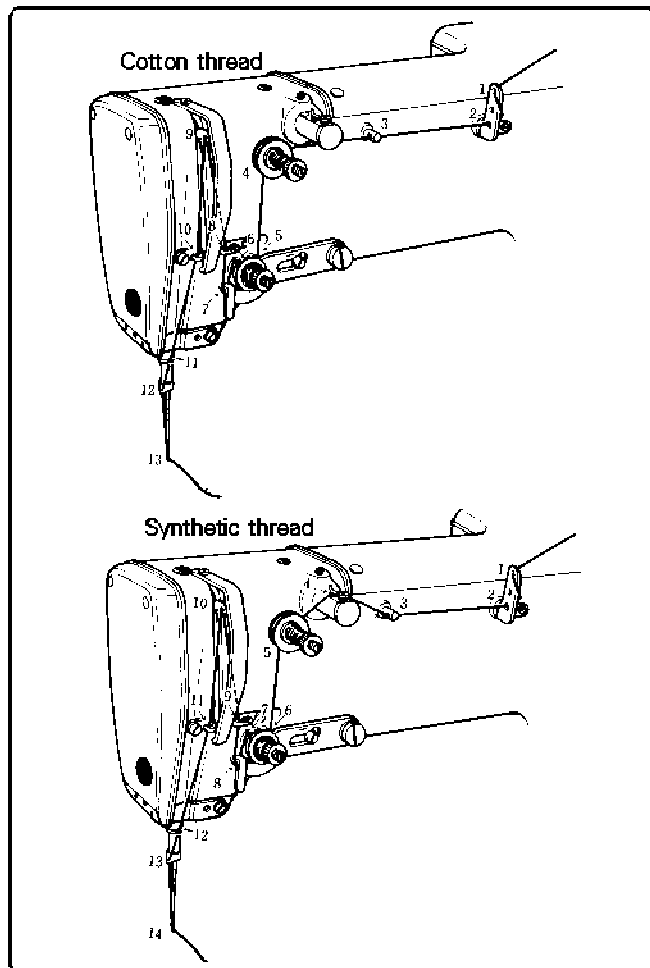

Thread the upper thread correctly as shown below.

Selecting a needle and thread

The type of needle and thread to be used differ according to the type of sewing to be done, and the table below is a guide to their selection.

Needle	Thread	Type of sewing
DP × 5#9	#100 ~ #80	Knitted goods
DP × 5#14	#80 ~ #50	Ordinary clothes
DP × 17#19	#30 ~ #10	Denim

Bobbin winding

1. Check that the power switch is turned on.
2. Set the bobbin ① on the bobbin winder spindle and push it up to the end.
3. Do threading as shown in the diagram on the left, and then wind the thread around the bobbin ① a few times in the direction of the arrow.
4. Press the bobbin winder stop latch ② and the thread will begin winding automatically. When a fixed amount of thread has been wound onto the bobbin (that is, the bobbin will be filled to 80% of its capacity), the bobbin winder stop latch ② will return to its original position.
5. Remove the bobbin ① and cut the thread with the thread cutter ③.

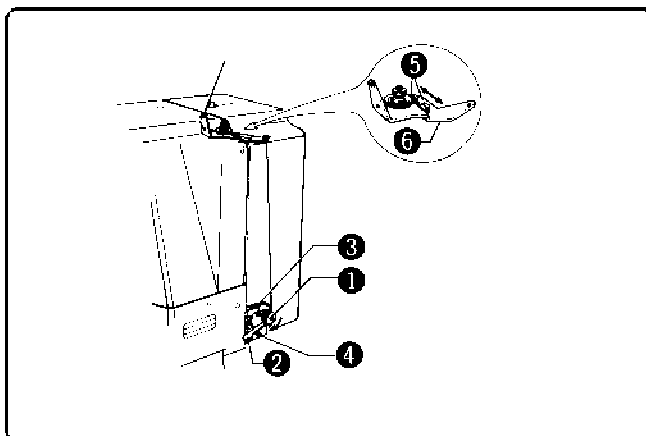

* If you wish to wind more than the fixed amount of thread onto the bobbin, loosen screw ④ and let the bobbin winder stop latch ② move downwards. The bobbin can then be filled up to this position of the stop latch.

★ When the thread piles up to one side; If the thread piles up to one side of the bobbin while being wound, loosen the two screws ⑤ and adjust the position of the bobbin winding thread guide ⑥.

Inserting and removing the bobbin case and lower threading

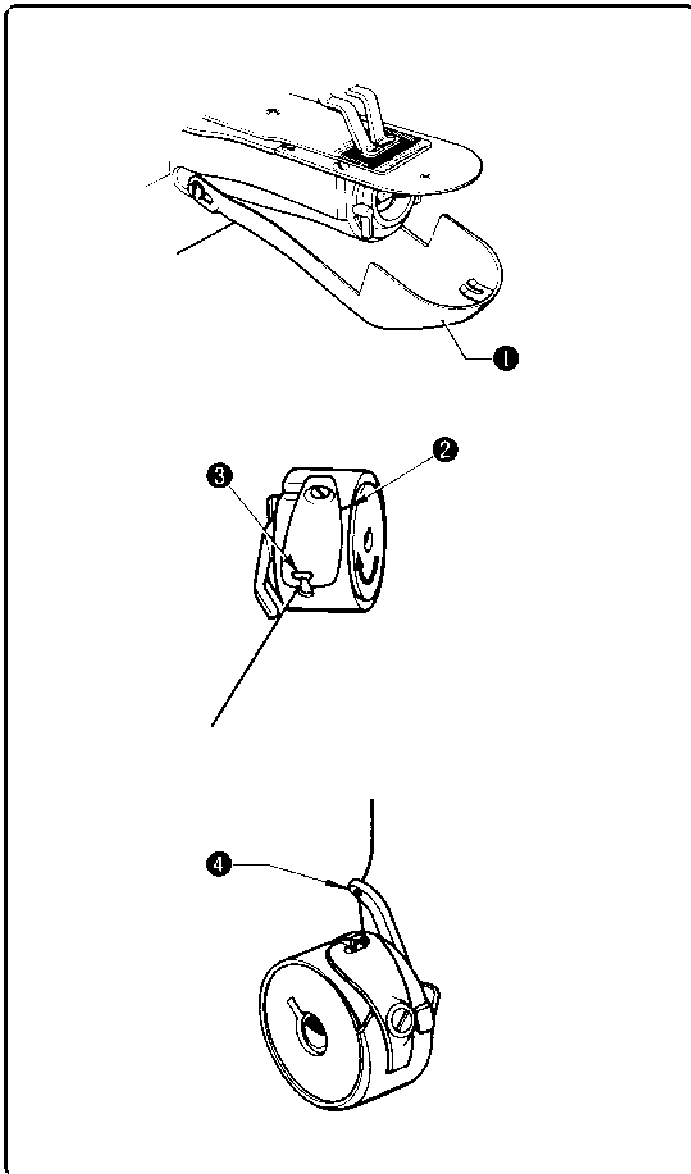

1. Pull the shuttle race cover ① towards you and then open it.
2. Place the bobbin inside the bobbin case, and then draw the thread through slot ② and out of the delivery eye ③. While doing this, check that the bobbin is revolving in the direction of the arrow.
3. Pass the end of the thread through the tension bracket hole ④ and draw it out to a length of about 30mm.

Lower thread tension

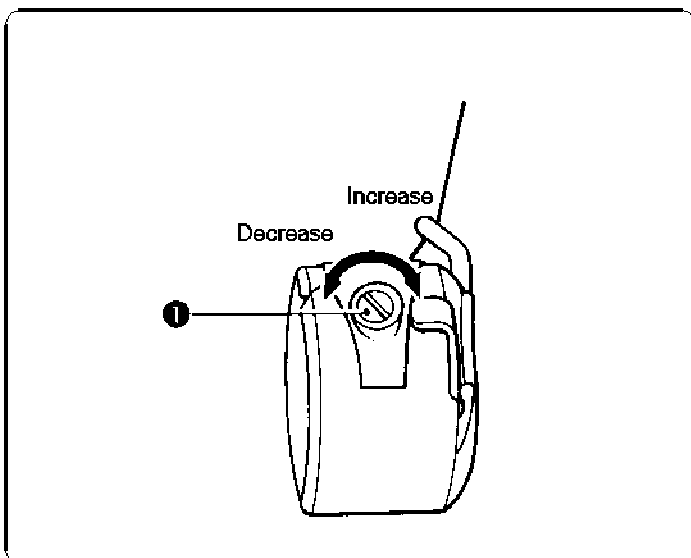

Hold the bobbin case by the end of the thread, and then adjust the lower thread tension by turning the regulating screw ① to reduce the tension until it is just strong enough to prevent the bobbin case from slipping and falling from its own weight. Turn the regulating screw to the right to increase the tension, and to the left to reduce the tension.

Upper thread tension

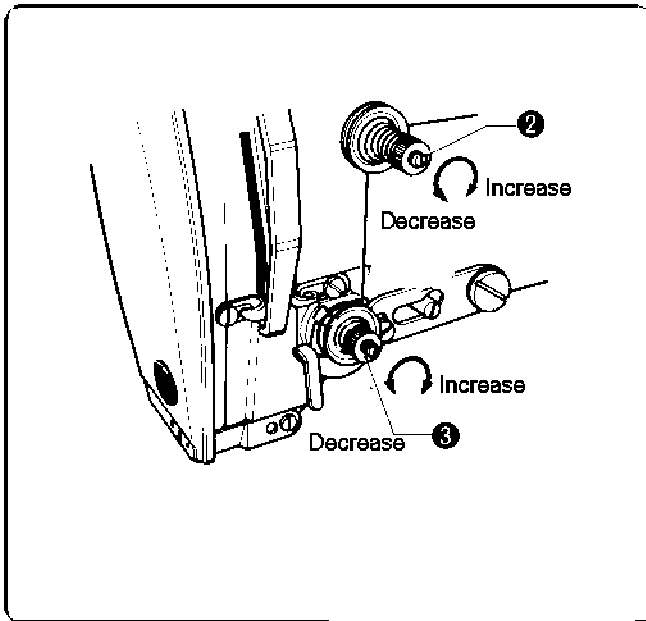

* With the machine at a standstill , turn the tension regulating thumb nut ② to reduce the auxiliary tension until it is just strong enough to prevent the thread from sagging between the needle and the cloth . Turn the thumb nut to the right to increase the tension, and to the left to reduce the tension.

* Adjust the main tension to suit the type of fabric being sewn by turning the tension regulating thumb nut ③. Turn the thumb nut to the right to increase the tension, and to the left to reduce the tension.

Thread take – up spring

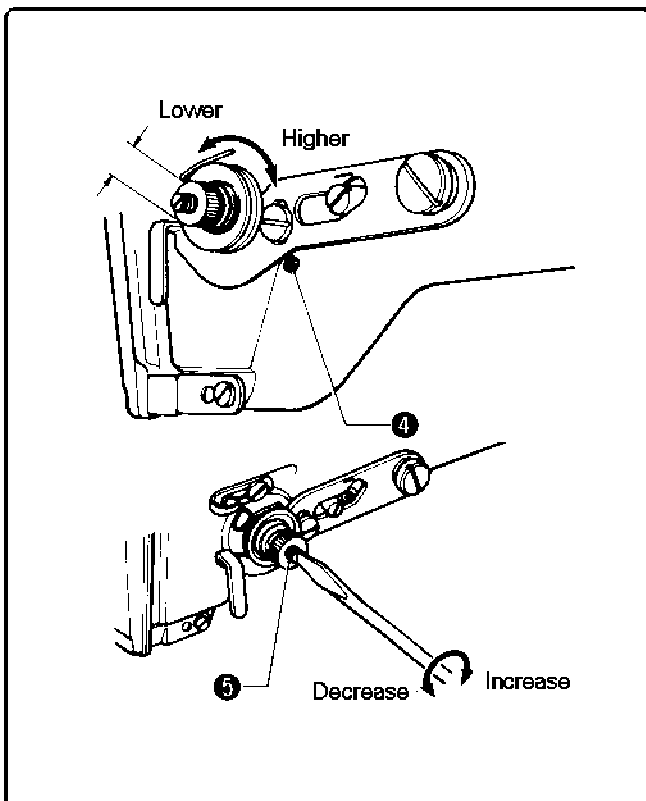

To adjust the height of the thread take – up spring , loosen screw ④ and turn the whole regulator. If you need to adjust the tension of the spring, turn the tension stud ⑤ with a screwdriver.

Using the stop lever

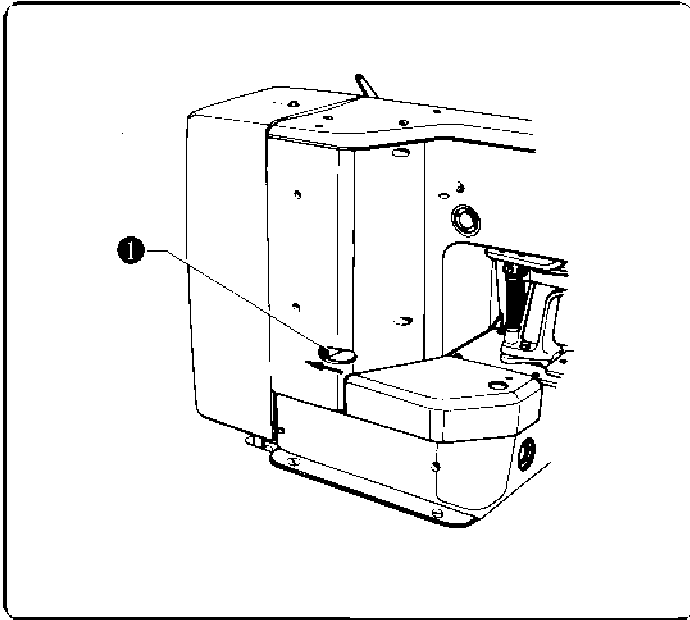

When the stop lever ① is pressed in the direction of the arrow, the thread will be trimmed and then the work clamp will rise and the machine will stop automatically.

Cleaning the shuttle race

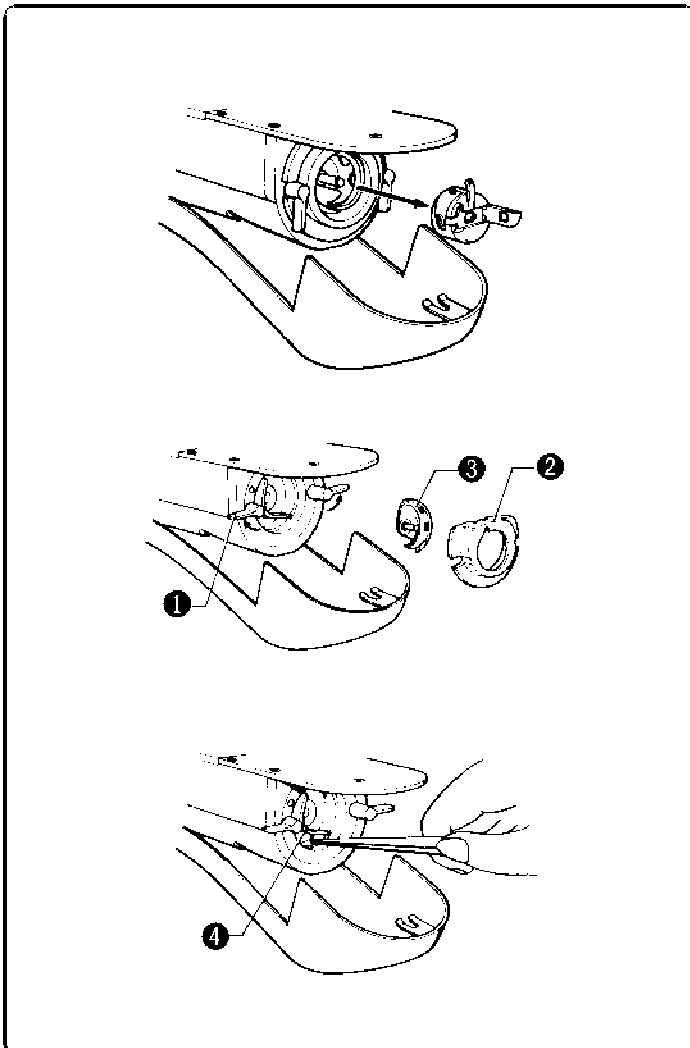

1. Pull the shuttle race cover towards you and remove the bobbin case.
2. Open the shuttle race catches ① in the direction of the arrows, and remove the shuttle race ring ② and the shuttle.
3. Remove any fluff and dust from the area around the shuttle driver ④, the upper part of the shuttle race thread guide, and the shuttle race itself. After cleaning apply a drop of oil to the shuttle race.

Replacing the fixed and moving blades

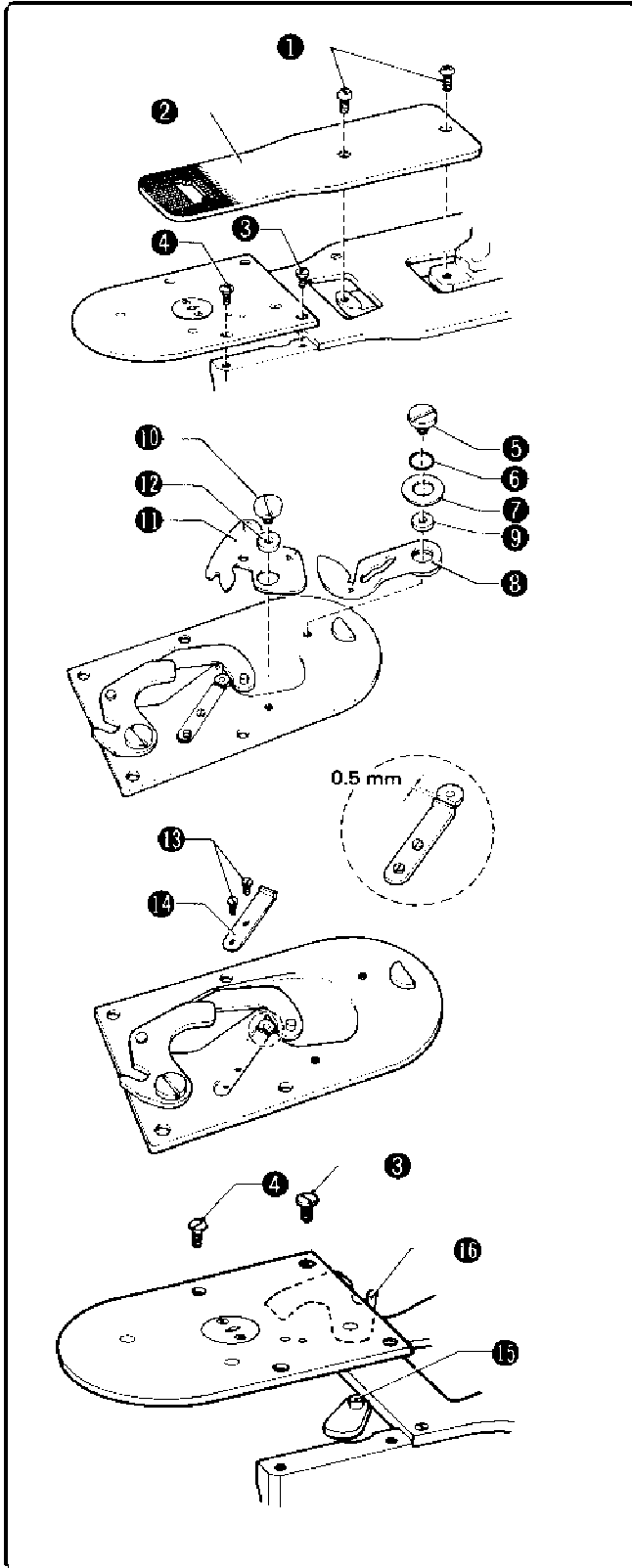

1. Open the shuttle race cover.
 2. Remove the screws ① and take out the feed plate ② .
 3. Remove the two clamping screws ③ and the two flat head screws ④, and take out the needle plate.
 4. Remove the screw ⑤, the O – ring ⑥, the washer ⑦, the lower thread guiding finger ⑧, and the collar ⑨ .
 5. Remove screw ⑩, take out the moving blade ⑪ and collar ⑫ , and replace the moving blade with a new one.
 6. Remove screws ⑬ and replace the fixed blade ⑭ with a new one. When doing so, move the fixed blade ⑭ to adjust the clearance between it and the needle hole plate to 0.5mm.
 7. After replacing the moving and fixed blade fit the thread trimmer arm C ⑱ over the pin ⑲ of the thread trimmer arm B. Fasten the needle plate in place with the two clamping screws ③ and the two flat head screws ④ .
- * After attaching the needle plate, once again check the position of the moving blade.

Needle bar height adjustment

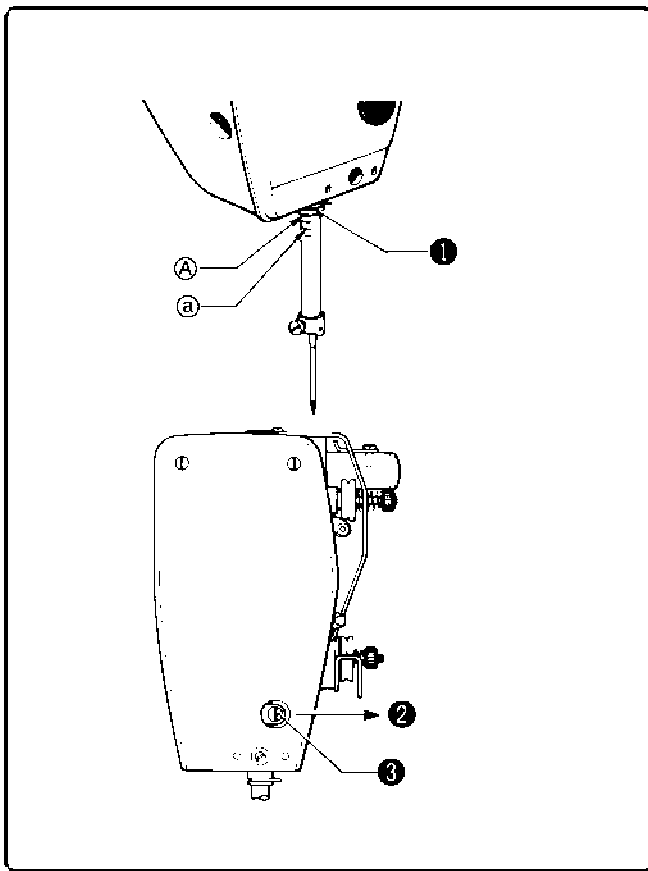

Turn the pulley until the needle bar reaches its lowest position. Adjust the position of the needle bar by removing the cap ②, loosening the screw ③, and moving the needle bar up or down until the uppermost reference line A on the needle bar is flush with the lower end of the needle bar bushing ①.

★ If using a DP ×17 needle, adjust the needle bar so that the reference line second from the bottom ② is flush with the base of the bushing

Needle bar stroke adjustment

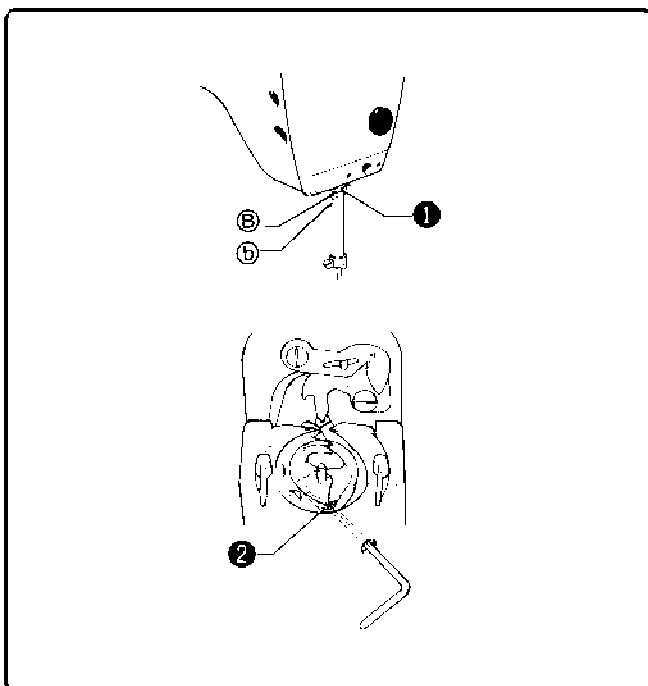

Turn the pulley to move the needle bar up from its lowest point and set the reference line B, second from the top of the needle bar, flush with the lower end of the needle bar bushing ①.

Then, with the needle bar in this position, loosen the hex bolt ② and move the shuttle driver so that the tip of the shuttle hook is in line with the center of the needle.

★ If using a DPX17 needle, adjust the needle bar so that lowest reference line ② is flush with the base of the needle bar bushing.

Shuttle driver and needle contact adjustment

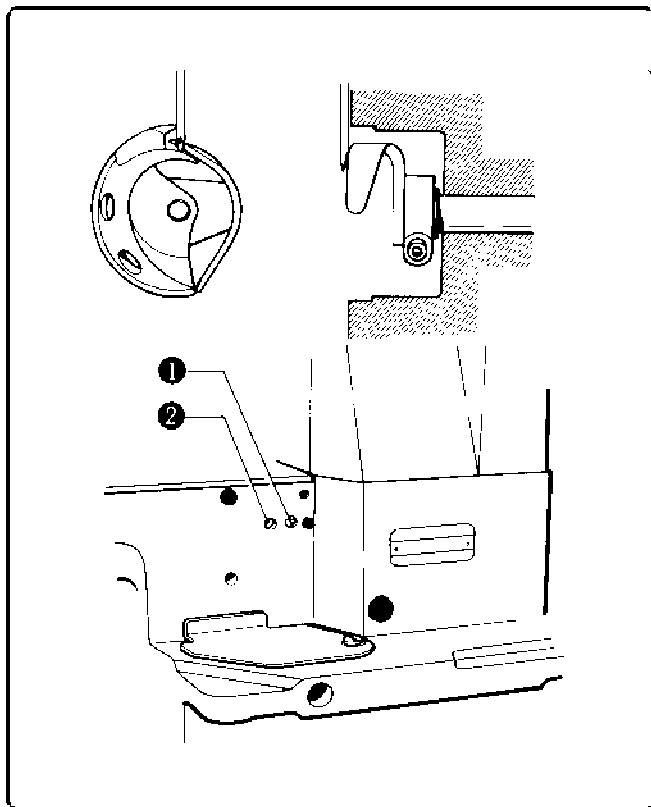

Turn the pulley to bring the tip of the shuttle hook into line with the center of the needle. Then loosen screw ① and turn the eccentric shaft ② so that the needle comes into contact with the shuttle driver. If the needle is received deeper than necessary it may cause skipped stitches. Again, if the needle does not contact the shuttle driver, the tip of the shuttle hook may be subjected to great wear and tear. Take care when making this adjustment.

Needle and shuttle hook clearance adjustment

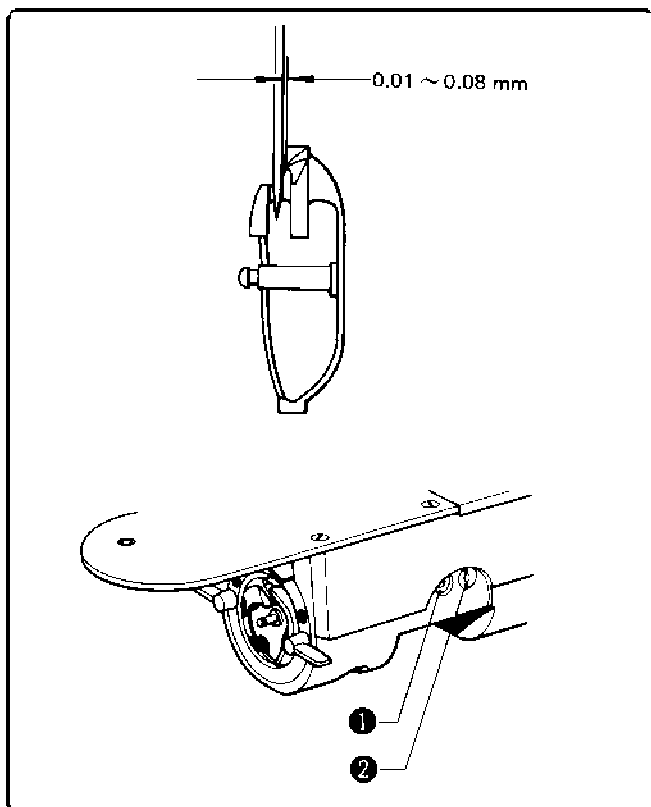

Turn the pulley to bring the tip of the shuttle hook in to line with the center of the needle. Then loosen screw ① and turn the eccentric shaft ② so that the clearance between the needle and the tip of the shuttle hook is between 0.01 and 0.08mm.

Shuttle race thread guide adjustment

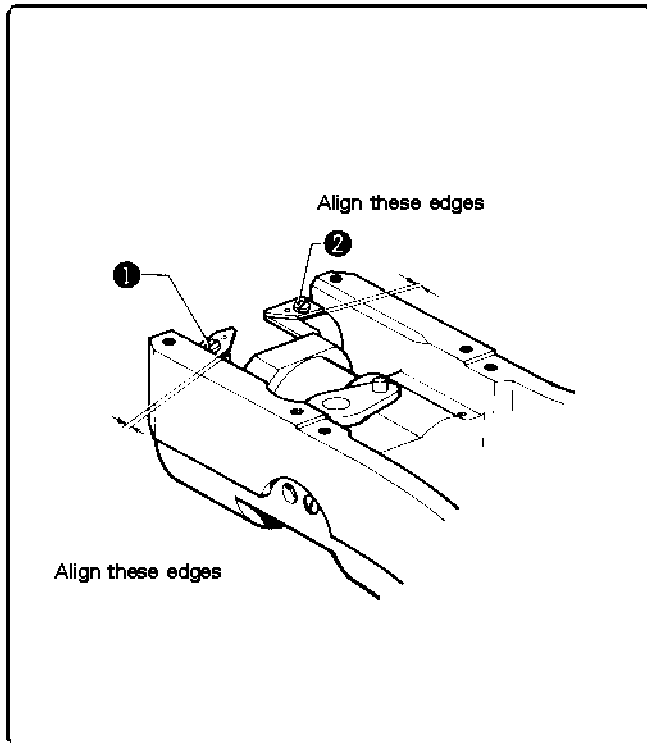

Adjust the position of the shuttle race thread guide by loosening screws ① and ② and moving the two parts of the thread guide so that they are in line and flush with the shuttle race body as in the diagram left.

Brake spring tension adjustment

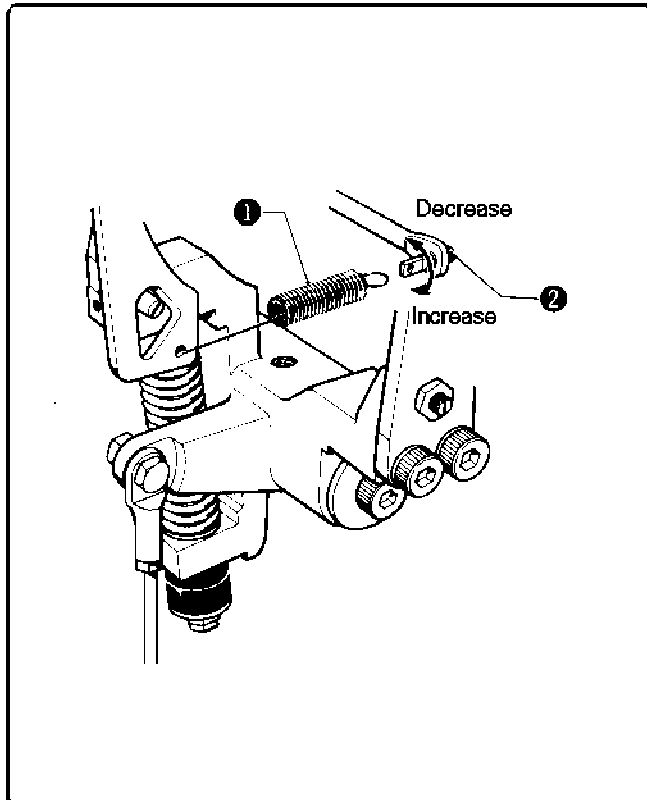

When very thick materials are sewn on a machine of standard specifications, frictional resistance becomes large and the stop cam may not turn as far as the stop position at the final stitch. If this happens, remove the brake extension spring ①, and turn the spring peg ② counterclockwise to reduce the tension of the brake extension spring ①.

Needle and feed timing adjustment

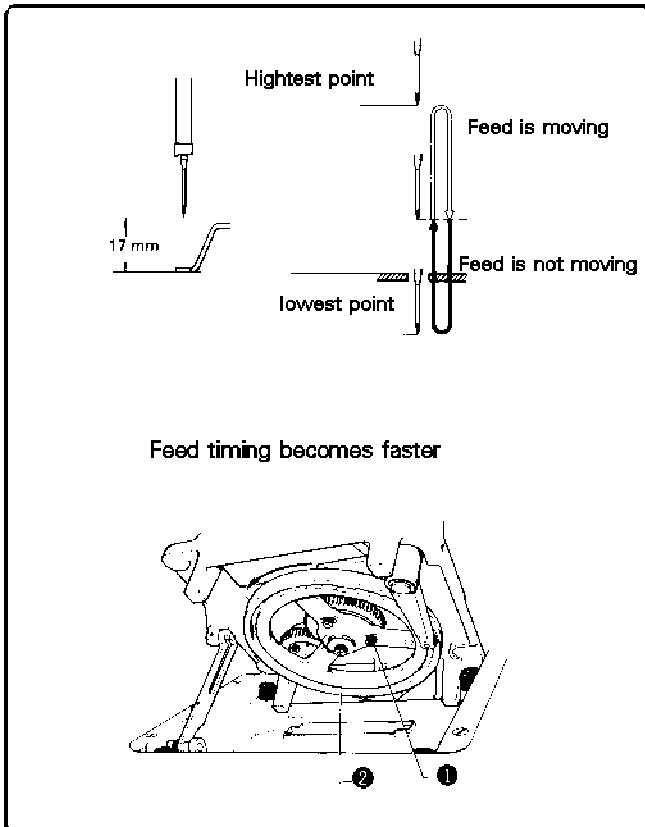

Adjust the needle and feed timing by loosening the three Allen bolts ① and turning the feed cam a little at a time, such that feed begins to operate after the needle is lifted from the cloth, and stops again before the needle pierces the cloth. The more the feed cam ② is turned in its normal rotating direction, the faster the timing becomes.

★ When sewing thick fabrics it is better to set the feed timing relatively later because this will decrease the likelihood of wayward stitching and ensure satisfactory tension.

Tread take – up lever adjustment

The stroke of the thread take – up lever can be reduced to a maximum magnitude of 7mm in order to prevent the thread from slipping out of the needle at the commencement of sewing. Adjust the stroke of the thread take – up lever to suit the type of material being sewn as follows.

1. Turn on the power switch and depress the pedal to the first step to lower the work clamp.
2. Turn off the power switch. After the machine has stopped completely, press the pedal down fully to raise the clutch.
3. Loosen screw ① and move the thread take – up guide shaft ② to the right to increase the stroke of the thread take – up lever ③, or to the left to decrease the stroke. However, because the thread tension becomes poor if the guide shaft is moved further than necessary, adjust the stroke so that the center of the thread take – up guide shaft ② is always with the range of the mark.
4. After marking the adjustment, turn on the power switch and set the machine back in normal working order.

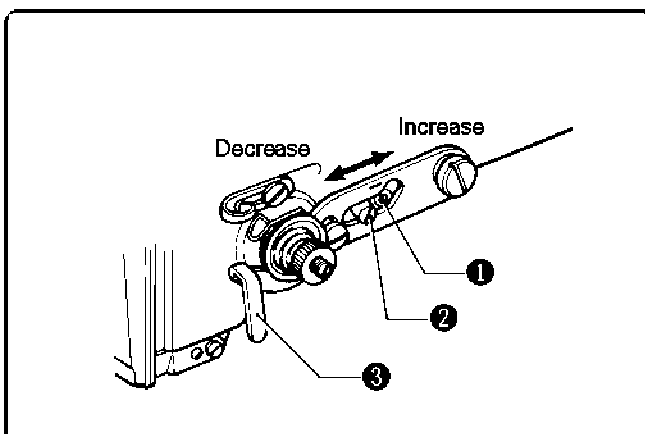

Tack length adjustment

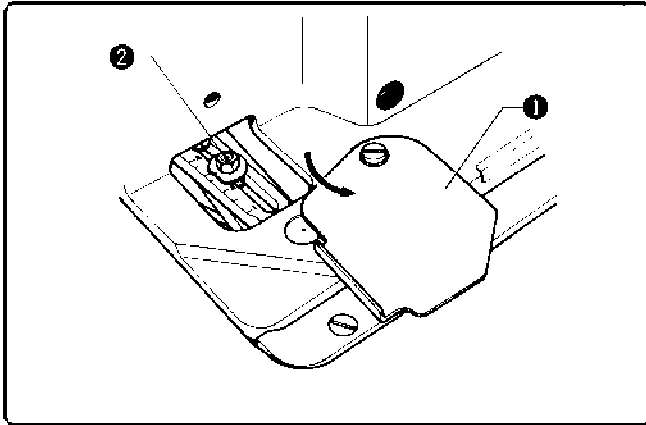

Open the cover ①, loosen the nut ②, and match the notch on the washer to the desired unit on the scale; tighten the nut ②. Use the scale as a standard, and finely adjust the length of the lock stitch stop by actually sewing.

Tack width adjustment

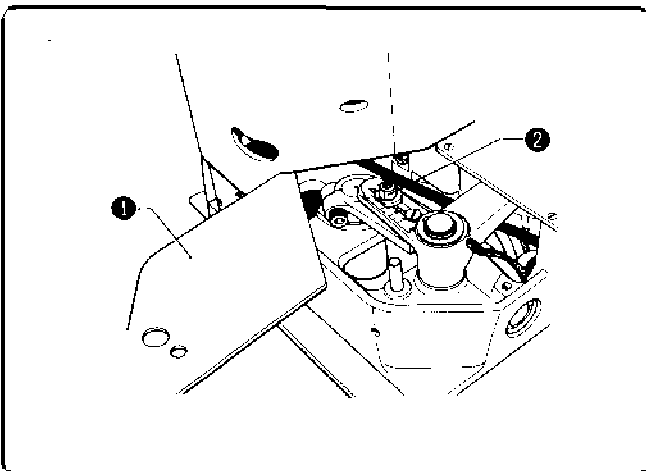

Open the cover ①, loosen the nut ②, and match the notch on the washer to the desired unit on the scale; tighten the nut ②. Use the scale as a standard, and finely adjust the width of the lock – stitch stop by actually sewing.

Work clamp stroke adjustment

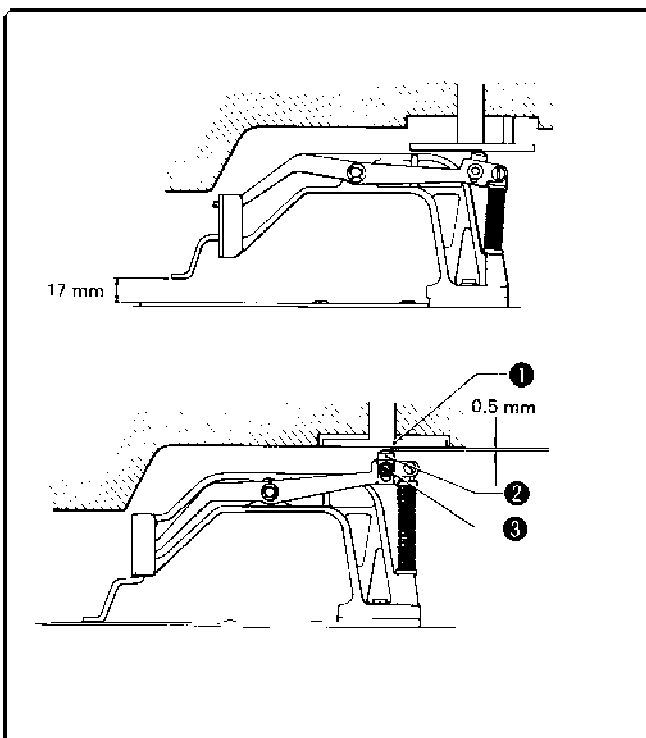

The maximum stroke of the work clamp when the machine is at a standstill is a distance of 17mm between the needle plate and the work clamp. Make this adjustment with the work clamp in the lowered position. Loosen screw ③ and move the presser arm lever plate ② up or down so that there is a clearance of 0.5mm between it and the presser lifter plate ①. The stroke of the work clamp can be reduced in the same way. As the clearance between the presser lifter plate ① and the presser arm lever plate ② is increased, the stroke of the work clamp decreases.

Moving blade position adjustment

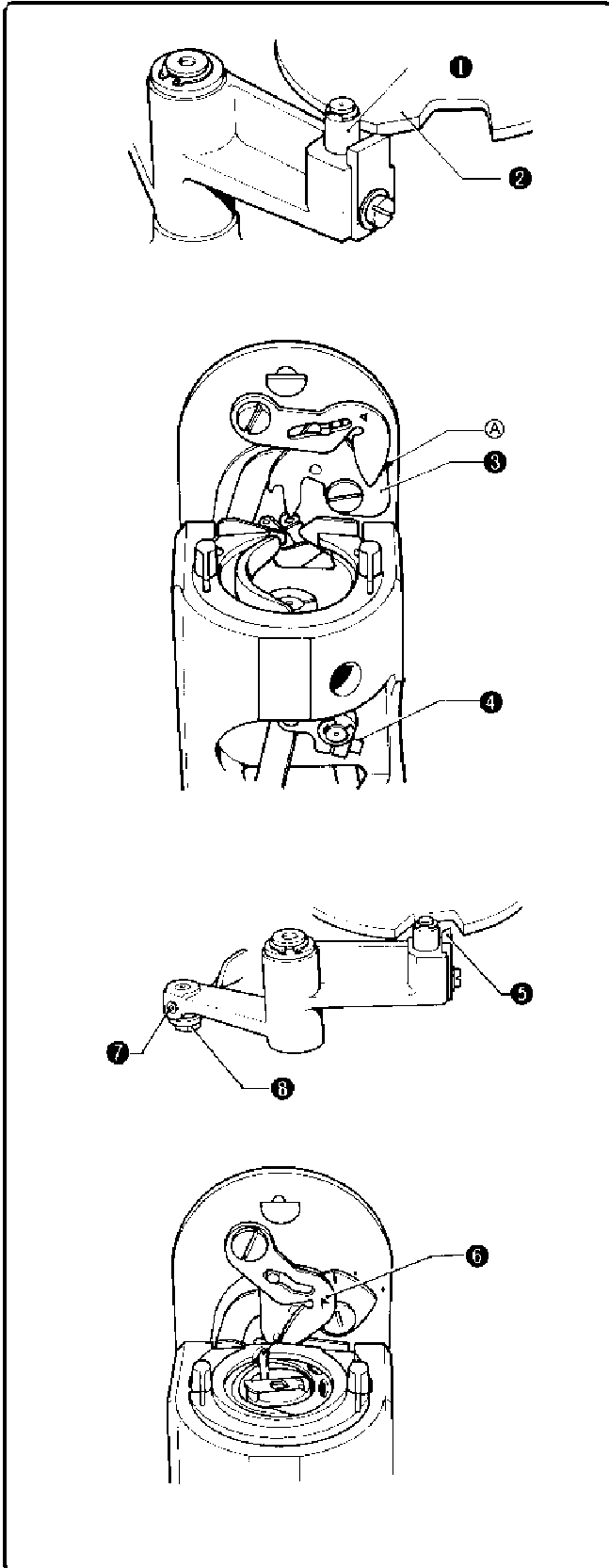

1. Turn the pulley, and when the ever roller ① of the thread trimmer moves up to the outer edge of the thread – trimmer cam ②, loosen the screw ④, and make an adjustment by moving the moving blade ③ in such a way that the take – in of the moving blade becomes aligned with the take – in A of the needle plate.
2. When the sewing machine is in the STOP mode (i. e., when work clamp is at the lowest position), turn the power – pulley gradually in the direction of rotation during operation until the claw ⑤ of the thread trimmer cam lever descends to the next level. At this time, loosen the set screw ⑦, and make an adjustment by turning the thread trimmer adjustment shaft ⑧ in such a way that the lower thread guiding finger ⑥ comes into contact with the lower thread.

Thread wiper adjustment

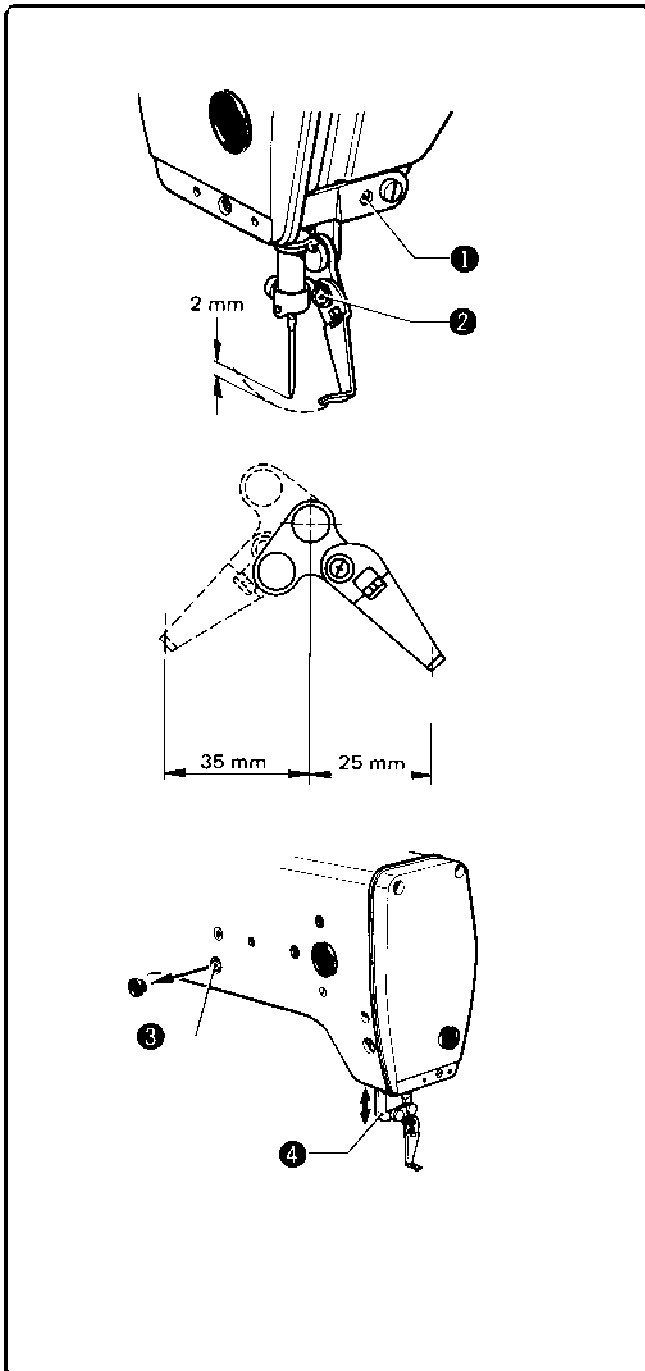

1. With the thread wiper aligned with the center of the needle bar, loosen screw ① and move the thread wiper frame support ② upward or downward so that the clearance between the thread wiper and the tip of the needle is 2mm.
2. Loosen the screw ③ and move the thread wiper connecting plate ④ upward or downward so that the thread wiper is at a distance of about 25mm from the needle before sweeping the thread upward, and at a distance of about 35mm from the needle after sweeping the thread.

Drive lever plate stopper A position adjustment

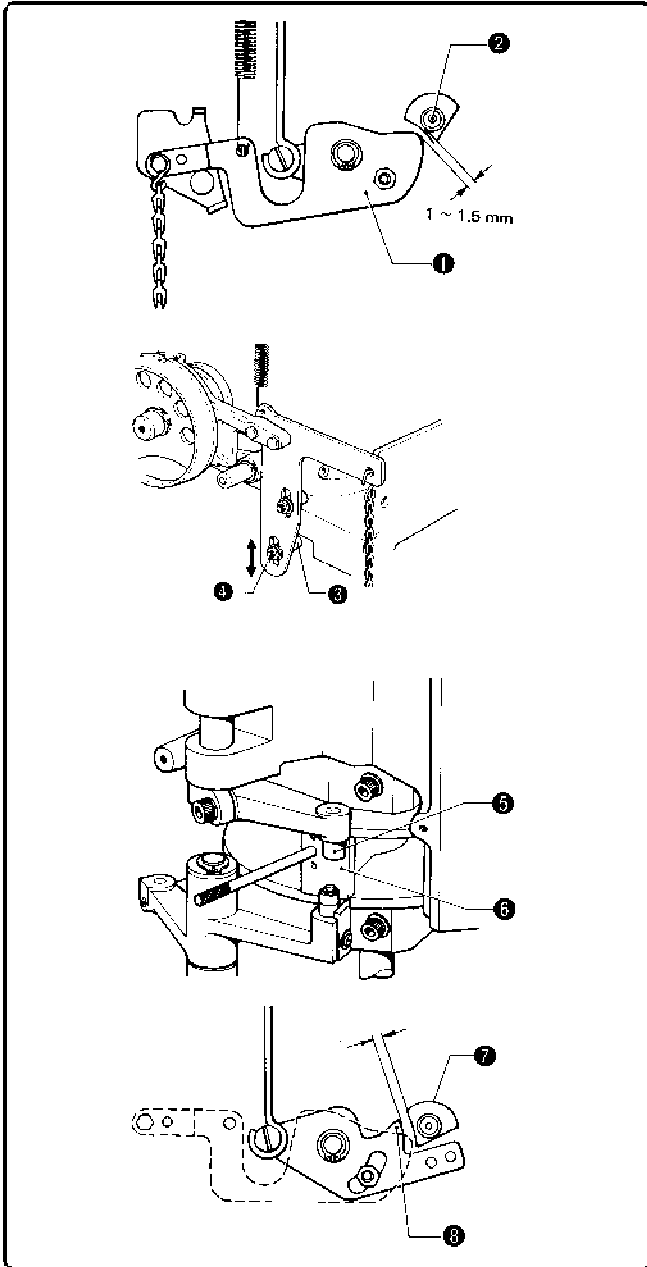

1. While the right pedal is being depressed, adjust stopper A ③ so that when the clearance between the right edge of actuating lever B ① and the presser – lifter roller ② is 1.5 – 2mm, stopper A ③ makes contact with the bottom surface of the bed. To make this adjustment, loosen the nut ④ and adjust stopper A ③ by moving it upward or downward.
 2. Turn the pulley by hand so that the clutch – operation – lever roller ⑤ comes to rest on the body of the roller holder ⑥ (high – speed condition). At this time check to be sure that there is a slight clearance between the projection of the drive lever claw ⑦ and the projection of the presser – lifter claw ⑧ when the drive – lever plate is lightly pressed by hand. If there is no clearance, readjust stopper A ③ .
- * Check the clearance between the projection of the drive lever claw ⑦ and the projection of the presser – lifter claw ⑧ by sense of touch (when pressing the drive – lever plate).

Drive lever plate stopper B position adjustment

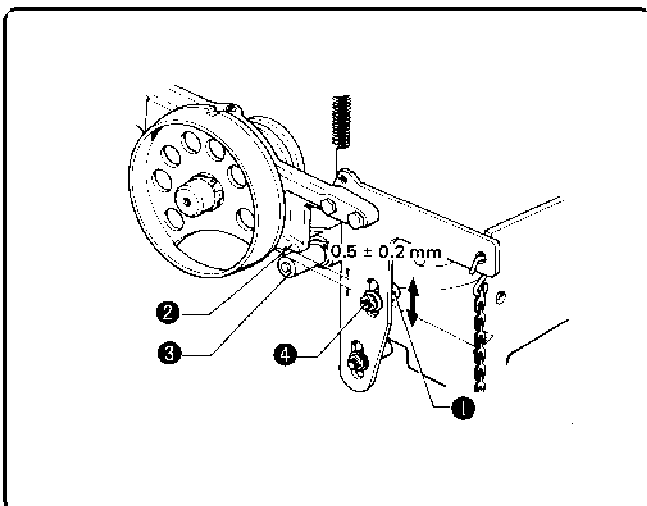

While the machine is not operating, depress the left pedal, and the loosen the nut ④ and adjust stopper B ① by moving it up and down so that the clearance between the drive – lever stopper part ② and the thread – trimmer operation lever axel ③ is 0.5 ± 0.2 mm when stopper B ① is in contact with the upper surface of the bed.

Kinds of machines

BT9430 

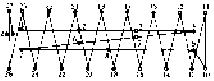
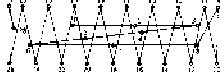
Sub - class	-011	-021 -022	-0311 -032	-041
Main uses	Ordinary clothes	Denim	Ordinary	Knitted clothes
Decorative stitching				
Number of stitching	42		28	
Tack length	7 ~ 16	7 ~ 20	4 ~ 10	4 ~ 8
Tack width	1 ~ 2	1 ~ 3	1 ~ 2	
Needle	DP x5#16	DP x17#19	DP x5#16	DP x5#9
presser foot stroke	17mm		17mm	
Sewing speed	2,000rpm		2,000rpm	

The maximum possible bar tack length and width for this machine are given above.

- Besides adjusting stitch, please laypeople don't debug or maintaine.
- Parts are subject to changes in design without prior notice.

XI'AN TYPICAL INDUSTRIES CO., LTD.

Add: No.1 Taibai South Road,

Xi'an, P. R. China - 710068

Tel : +86 -29 -88279091 88279150

Fax : +86 -29 -88248715 88245215

E-mail: typical@chinateypical.com

Http: www.chinateypical.com

Http: www.globalsources.com